

REPUBLIQUE ALGERIENNE DEMOCRATIQUE ET POPULAIRE

الجمهورية الجزائرية الديمقراطية الشعبية

MINISTRY OF HIGHER EDUCATION
AND SCIENTIFIC RESEARCH

HIGHER SCHOOL IN APPLIED SCIENCES

--T L E M C E N--



المدرسة العليا في العلوم التطبيقية
École Supérieure en
Sciences Appliquées

وزارة التعليم العالي والبحث العلمي

المدرسة العليا في العلوم التطبيقية

تلمسان-

End-Of-Study manuscript

To obtain the Master degree

Branch: Electrical engineering

Speciality: Energy and Environnement

Presented by: BARA Imene, KERROUM Raghed

Theme

Development of a predictive model for photovoltaic cells performance evaluation

Publicly presented, on 07 / 07 / 2020, Infront of the committee:

Mr. Maliki Fouad	Professor/MAA	ESSA. Tlemcen	Committee President
Ms. GHOMRI Amina	Professor/MCA	ESSA. Tlemcen	Supervisor
Mr. Chiali Anisse	Professor/MCB	ESSA. Tlemcen	Examiner1
Ms. KHERBOUCHE Djamila	Professor/MCB	ESSA. Tlemcen	Examiner2

University year: 2019/2020

Dedication

To The sake of Allah, my Creator, our messenger and great teacher, Mohammed (peace be upon him), who taught us the purpose of life.

*To my dearest parents, **Ahmed** and **Aicha** to whom my gratitude and appreciation could never be expressed, for never stopping to give in countless ways, for making me the person I am today.*

May god protect them.

To my Brothers, my uncle, my aunts, cousins and many friends.

*Special thanks to my cousin **elmassa**, for her help and encouragements.*

*To **Imene**, whom I am extremely proud of and grateful for.*

I dedicate this research.

Raghd KERROUM.

Dedication

I thank almighty God for the courage and strength that he has given me to finish this work,

*To my mother **Zohra** and my father **Mohammed**, who have never stopped praying for me and encouraging me, may God protect them,*

*To my whole family, from the biggest to the smallest. To my sisters **Safa** and **Fethia**, to my brothers **Nabil** and **Abd latif**.*

*To my friends, **Khadidja**, **Housseem** and **Imad**,*

*To **Raghd**,*

You have worked hard for me without counting the cost, in recognition of all the sacrifices made by each and every one of you to enable me to reach this stage of my life. With all my tenderness.

I dedicate this thesis.

Imen BARA.

Acknowledgements

Researching, executing, and compiling this report was a very challenging and rewarding experience for us. We have gained rich knowledge and, valuable experience through our thesis work. Although this is presented as our work, we could not have completed it without the help of God. So, first and above all, we praise our God and lord, the almighty for providing us with all of the strength, courage and success throughout our education journey and especially through this hard period of time. Thank you, god, for allowing us to finish our journey and for giving us the ability to write this thesis.

Apart from our efforts, this thesis' success depends largely on the motivation and guidelines of many others. We would like to make this an opportunity to express our gratitude to the people who have been influential in the successful completion of this thesis.

We would like to express our deepest appreciation to our mothers, our life mentors, strong women who have been through a lot and yet stood still, always encouraging, supporting and leading us to the success path with their valuable advices, patience, precious time and hard work spent in our favor.

We are deeply indebted to our fathers, who always trusted us in every step we took, who never gave up on us, worked hard for our sake and gifted us with their eternal love.

*We extend our sincere thanks to our supervisor, Misses **Amina GHOMRI** a professor and MCA, for giving us the opportunity to work with her, we admire her guidance, decision-making skills, orientation and of course the trust she gave us throughout the whole working process.*

This journey would not have been possible without, our teachers and course instructors, our school, the superior school of applied science and its academic staff; fellow classmates with whom we spent 3 years filled with beautiful memories, fun moments of laughter and joy, and from whom we have learned plenty of lessons. Thank you for all of you and every one of you.

*Finally, special thanks to **Mr. Maliki Fouad**, head of department of industrial engineering speciality, a professor and MAA at the Superior school of applied science, Tlemcen; to **Mr. Chialli Aniss**, the responsible of the exterior relations, a professor and MCB at the Superior school of applied science, Tlemcen; to Misses **KHERBOUCHE Djamila**, a professor and MCB at the Superior school of applied science, Tlemcen for taking some of their busy and precious time to discuss and enrich our work.*

We did not inherit this world from our parents. . . .

We are borrowing it from our children.

(Author unknown)

Earth is what we all have in common,

We hope that this thesis is helpful to students, researchers and engineers,

Who are willing to take part in the creation of a safe world for the future generations.

List of figures

Figure 1: white light spectrum	16
Figure 2: Longitude and latitude of a point M on the earth's surface.	17
Figure 3: Seen from the earth, the sun appears to follow a circular path around an axis of apparent rotation passing approximately through the North Pole Star. Same thing happens to the stars by night. The only star that is motionless is the North Star.	17
Figure 4: Apparent daily path of the Sun in the sky throughout the year for an observer in the Northern (left) and Southern Hemispheres (right).	17
Figure 5: Four (04) remarkable positions of the earth in relation to the sun. The axis of rotation of the earth is inclined with respect to the vertical to the ecliptic plane at an angle $23, 43^\circ$. This results in declinations of the sun-earth direction relative	18
Figure 6: On a solar diagram, the heights are plotted on the vertical axis and the azimuths are plotted on the axis horizontal. The position of the sun in the sky at a given moment is represented by a point on the plane.	19
Figure 7: Components of solar radiation.....	20
Figure 8: Pyranometer for Measuring the irradiance of a Solar Farm, in a Solar Cell Factory.....	21
Figure 9: Radiation surface properties.....	22
Figure 10: Current/voltage characteristic of a PV cell: a) dark, b) under illumination, c) equivalent diagram of an ideal solar cell under illumination.	25
Figure 11: Equivalent circuit of a solar cell.....	25
Figure 12: Different speeds according to illumination power.	27
Figure 13: Monocrystalline silicon cell.....	28
Figure 14: Monocrystalline silicon cell.	28
Figure 15: Amorphous silicon cells	28
Figure 16: Typical energy transformation path in a grid connected PV system	30
Figure 17: example of an off grid photovoltaic system.....	31
Figure 18: example of a grid connected system.....	31
Figure 19: PV system including shunt charge regulator	33
Figure 20: PV system including series charge regulator	33
Figure 21: PV system including MPPT controller.....	33
Figure 22: Overview of solar cell applications and of several types of solar cells used in different applications.	38
Figure 23: I(V) characteristics of a PV cell.....	51
Figure 24: P(V) characteristics of a solar cell	52
Figure 25: ideal model of a solar cell	53
Figure 26: real model of a solar cell.....	53
Figure 27: Two diode model	54
Figure 28: Characteristic I (V) of a module for different series resistance values.....	55

Figure 29: effect of the shunt resistance on the I-V characteristic of an illuminated solar cell.....	56
Figure 30: influence of the saturation current on the I-V characteristic of an illuminated solar cell. Characteristics formed by simulation using the following selective values: ($R_s=0.0364 \Omega$, $R_{sh}=53.7634 \Omega$, $I_s=0.3221 \times 10^{-6}$: 2.0×10^{-7} : 0.9221×10^{-6} A, $n=1.4837$, $t=33^\circ\text{C}$,.....	56
Figure 31: influence of the ideality factor on the I-V characteristic of an illuminated solar cell. Characteristics formed by simulation using the following selective values: ($R_s=0.0364 \Omega$, $R_{sh}=53.7634 \Omega$, $I_s=0.3223 \times 10^{-6}$, $n=1.48$: 5.0×10^{-2} : 1.63 , $t=33^\circ\text{C}$, $I_{ph}=0.7608$ A)	57
Figure 32: influence of temperature on I(V) and P(V) characteristics	58
Figure 33: Characteristic I (V) and P(V) of a module for different illuminance values.....	59
Figure 34: Module characteristics as a function of shading rate, where: A-current-voltage, B-power-voltage	60
Figure 35: equivalent circuit of a DSSC.....	62
Figure 36: DSSC equivalent circuit model.....	63
Figure 37: equivalent circuit of a DSSC.....	63
Figure 38: influence of Serie resistance on the DSSC	64
Figure 39: influence of shunt resistance on the DSSC	65
Figure 40: A 1×1 cm ² size DSSC unit cell.....	65
Figure 41: influence of temperature on DSSC	66
Figure 42: influence of radiation on DSSC	66
Figure 43: scatter plot and regression line on Origin.....	84
Figure 44: scatter plot and regression line on excel.....	84
Figure 45: parameters simulated in Origin.....	85
Figure 46: parameters simulated in Excel.....	85
Figure 47: scatterplot and regression line of T and G.....	86
Figure 48: results of parameters simulation on origin.....	86
Figure 49: scatterplot and regression line of T and P_{max} on Origin.....	87
Figure 50: results of regression parameters simulation on Origin.....	87
Figure 51: simulation of both T and G with P_{max} on Excel	87
Figure 52: scatter plot and regression line of G and P_{max} on Origin	88
Figure 53: scatter plot and regression line of the corrected model on excel	88
Figure 54: results of parameters simulation on Origin.....	89
Figure 55: final parameters simulation on excel.....	89

List of tables

Table 1: Effect of shadow on the DSSC parameters.....	67
Table 2: specification of the measurement system.....	81
Table 3: effect of partial shading on PV power generation parameters	81
Table 4: The performance parameters under different levels of solar irradiation and temperatures.	81
Table 5: Variation of the maximum power as a function of the number of cells shaded.....	84
Table 6: Variation of the maximum power as a function of the number of cells shaded.....	85

TABLE OF CONTENTS

LIST OF FIGURES	3
LIST OF TABLES.....	5
GENERAL INTRODUCTION.....	8
1 CHAPTER01 : GENERALITIES.....	12
1.1 INTRODUCTION.....	13
1.2 INTRODUCTION TO SOLAR ENERGY	14
1.2.1 Solar radiation.....	14
1.2.2 Variation of solar radiation as a function of the earth's movements.....	15
1.2.3 Solar spectral distribution.....	18
*Direct radiation.....	18
*Scattered radiation.....	18
*The albedo.....	19
1.3 MEASURING SUNLIGHT.....	19
1.3.1 The pyranometer.....	20
1.4 SURFACE PROPERTY	20
1.4.1 Black body radiation.....	20
1.5 PHOTOVOLTAIC CELLS.....	21
1.5.1 Photovoltaic effect and the p-n junction	21
1.5.2 Energy band gap	21
1.5.3 Doping	23
1.6 PHYSICAL CHARACTERIZATION OF PHOTOVOLTAIC CELLS [14].....	23
1.6.1 Current/voltage characteristic and equivalent circuit.....	23
1.6.2 Photovoltaic cell parameters [15].....	25
1.7 MAIN TYPES OF SOLAR CELLS.....	26
1.7.1 Inorganic photovoltaic cells.....	26
1.7.2 Organic photovoltaic cells.....	28
1.8 PHOTOVOLTAIC CONVERSION SYSTEM.....	29
1.8.1 STAND ALONE / OFF GRID.....	29
1.8.2 GRID CONNECTED.....	30
1.8.3 power generation.....	31
1.8.4 Control system (regulation system).....	31
1.8.5 Converter system.....	33
1.8.6 Energy storage.....	33
1.9 ECONOMICS	33
1.9.1 solar energy is free, but what does it cost?.....	33
1.9.2 Cost of Energy [21].....	34
1.9.3 PV cost [22].....	35
1.9.4 Life cycle cost [23].....	35
1.10 PHOTOVOLTAIC APPLICATIONS.....	36
1.11 ENVIRONMENTAL IMPACT	37
1.11.1 Environmental Effects of PV System Production.....	38
1.11.2 Environmental Effects of PV System Deployment and Operation.....	39
1.12 REFERENCES.....	40
2 CHAPTER02: ANALYSIS AND EVALUATION OF THE IMPACT OF ENVIRONMENTAL CONDI- TIONS ON PV CELLS PERFORMANCE BASED ON THE I-V CURVE	42
2.1 INTRODUCTION.....	43
2.2 WHY SHOULD WE STUDY OR PREDICT THE PERFORMANCES OF THE PV CELL? [1].....	43
2.3 EXTERNAL SOLAR CELL PARAMETERS [2].....	45
2.3.1 Short-circuit current density.....	45
2.3.2 Open-circuit voltage.....	46
2.3.3 Fill factor.....	46
2.3.4 Conversion efficiency.....	46
2.4 CHARACTERISTICS	47
2.4.1 the characteristic equation of the photovoltaic cell.....	47
2.4.2 Characteristic I(V).....	47
2.4.3 Characteristic P(V).....	47
2.5 ELECTRICAL MODEL.....	47

TABLE OF CONTENTS

2.5.1 One diode model.....	48
2.5.2 Two diode model.....	50
2.6 ELECTRICAL PARAMETERS INFLUENCING THE PERFORMANCE OF A PHOTOVOLTAIC CELL.....	50
2.6.1 Influence of the Serie resistance.....	51
2.6.2 Influence of the shunt resistance.....	51
2.6.3 Influence of the saturation current (I_s).....	52
2.6.4 Influence of the ideality factor (n).....	53
2.7 ENVIRONMENTAL PARAMETERS INFLUENCING THE SOLAR CELL.....	54
2.7.1 Influence of temperature.....	54
2.7.2 Influence of illuminance:.....	55
2.7.3 Shading influence.....	56
2.8 DSSC.....	56
2.9 EQUIVALENT CIRCUIT OF A DSSC.....	57
2.10 PARAMETERS INFLUENCING THE PERFORMANCE OF A DSSC.....	60
2.10.1 Influence of electrical parameters.....	60
2.10.2 Influence of environmental parameters.....	61
2.11 CONCLUSION.....	62
2.12 REFERENCES.....	63
3 CHAPTER03: PREDICTION MODEL FOR PV PERFORMANCE WITH CORRELATION ANALYSIS OF ENVIRONMENTAL VARIABLES.....	3
3.1 INTRODUCTION.....	65
3.2 HISTORY.....	66
3.3 DEFINITION.....	66
3.4 CORRELATION.....	67
3.4.1 Correlation coefficient.....	67
3.4.2 Collinearity and variable selection.....	68
3.5 SIMPLE LINEAR REGRESSION.....	68
3.5.1 Assumptions.....	69
3.5.2 least squares method.....	69
3.5.3 Different entries in the simple linear regression model.....	70
3.5.4 Analysis of variance equation.....	70
3.6 MULTI LINEAR REGRESSION.....	71
3.7 SYSTEM STUDIED.....	72
3.8 DATA USED FOR THE STUDY.....	73
3.9 PREDICTION MODEL OF PV POWER.....	74
3.9.1 Pre-work.....	74
3.9.2 Results and discussion.....	75
3.10 CONCLUSION.....	83
3.11 REFERENCES.....	84
GENERAL CONCLUSION.....	85
ABSTRACT.....	87
RESUME.....	87
ملخص.....	87

General introduction

General introduction

Energy is the basis of all human activity, the use of renewable energies is very old in the history of mankind, renewable energies were for a long time the first possibility to produce energy. This only changed with the industrial revolution in the 19th century with coal and the discovery of steam engines and in the light of the 20th century with the appearance of oil, gas and nuclear power. This, weakened the application of renewable energy. Actually, a large part of the world's energy demand is met from fossil resources. However, the fossil fuel reserves are limited. Some developed countries have oriented towards nuclear energy, even though it has a high risk of serious accidents. Nevertheless, these fossil fuels are a major cause of pollution and climate change. Consequently, the emission of greenhouse gases is one of the undesirable side-effects of fossil fuels, whereas the greenhouse effect is a natural phenomenon that keeps the surface of the earth's atmosphere at a constant temperature [1]. In recent decades, the scientific community has been observing global warming, a phenomenon that appears to be increasing and accelerating. Although the influence of greenhouse gases on the climate remains complex, the increase in global warming is not yet fully understood, their constant concentration worries scientists. Increasingly extreme and unexpected climatic phenomena are being observed [3]. Because energy consumption in developed countries is high due to industrialization, and it is growing rapidly in developing countries due to their high population growth, urbanization and economic development. Greenhouse gas emissions from all countries in the world will soon become dangerous. The deterioration of the environment caused by these types of energy has prompted the development of new, renewable sources of energy, thus ensuring sustainability and environmental protection, which has become a very important issue. Consequently, the development by scientists of ingenious technologies of renewable energy conversion systems to replace energy applications produced by traditional fuels remains a mandatory duty. Renewable energy sources have a decisive place in the future, as they present the basis for the production of electrical energy of the future, as these forms of energy are inexhaustible, clean and more environmentally friendly, and therefore their non-polluting aspect is characterized by clean energies. These energies are our solution to meet the rising demand of energy and protect the environment not only for current generations but strongly for future generations.

Within the framework of the amplification and vulcanization of these new energy resources, several systems have been developed, proposed and implemented to meet current requirements. Examples include solar, wind, geothermal, hydro and biomass energy, which are attracting attention in terms of large-scale power generation.

Of all the renewable energies, the photovoltaic conversion of solar energy into electricity is an attractive option, it is the most abundant and fairly distributed with about 3.9×10^{24} joules of solar energy reaching the earth annually [2]. Especially if we look at its energy conversion efficiency (i.e. the ratio of the electrical energy produced to the primary energy supplied, here radiated by the Sun), which is close to 25% in the laboratory and 16 to 17% in industrial production without concentration. The efficiency of a system based on the combustion of a fossil ore is at best 30-35%, i.e. at the level of what can be done in photovoltaics with the concentration of solar radiation, so it is reasonable to expect that solar electric power can become profitable as early as the middle of the 21st century [4]. Photovoltaic (PV) solar energy is an inexhaustible green energy that represents an alternative source of energy that can be used by humanity. This energy is moreover applied in various fields ranging from residential installations and commercial to space systems, because of the many advantages such as pollution-free, it is noiseless, easy to install, and requires a short period of time to install. However, it presents a common disadvantage by its unpredictability and dependence on changing weather and climate conditions.

The use of solar cells as solar energy converters has revealed the need to study these systems in order to optimize them, and consequently to develop the exploitation of this new source of clean renewable energy that does not emit greenhouse gases.

In a PV solar station that may comprise hundreds or even thousands of PV panels, the stability and quality of the power generated correlates with the operating state of each cell. The challenge in this type of installation is how to monitor the huge array of photovoltaic cells in order to maintain normal operation of the station [5]. Generally, PV generators are considered reliable compared to other systems, but like all systems process, a PV system can be exposed to several failures causing it to malfunction, several studies have found that the reliability of PV systems is highly dependent on the material used to build the PV panels, temperature, humidity and solar radiation. A PV system can have several defects, mainly the material and electrical defects caused by weather/ environmental conditions.

In addition, the operation of a PV generator in the presence of several faults and anomalies causes a drop in performance or even the total unavailability of the system. All its unfavorable consequences will obviously reduce productivity, and thus reduce the profit of the installation, not to mention the cost of maintenance to bring the system back to normal. Taking this in account, there is a continuing interest among PV installers, regulators and owners to obtain accurate information about PV systems operating under conditions of different weather/ Environmental variables or let's say incompatible operating conditions that are sometimes unavoidable.

Illuminance, temperature and shading are three extremely important parameters in the behavior of solar cells. They greatly influence the I-V characteristic of the solar cell. Hence, the importance of studying their influence to optimize the performance of photovoltaic systems since they are exposed to solar radiation and they could easily be shaded.

To do so, engineers and scientist are coming up with methods to predict the performance of solar cells in accordance to environmental factors before they could even start functioning. In the literature, there are several methods built for performance prediction, detection and localization of faults, whether for industrial systems in general, or for photovoltaic stations.

In this respect, it is in this context that our master thesis flows. Indeed, the objective is the Development of a predictive model for the performance of solar cells involving environmental variables, for a better examination of these effects, using a statistical method based on the study of correlation between environmental variables. At the end, we will establish a mathematical modal from which we can predict the PV power.

To this end, the thesis is structured in three detailed chapters as follows:

The first chapter deals with the various generalities essential for a good assimilation of the principles of solar photovoltaics. we recall some generalities about the fundamental source of photovoltaic energy; the sun, its energetic power and the properties of its energy; and then we describe the converter element; the solar cell. We discuss its structure, its electrical characteristic, its equivalent electrical circuit, the parameters, the mechanism of photovoltaic conversion, the grouping of solar cells into modules to build a photovoltaic field; we mention the different types of solar cells and then we finish with economics and environmental impacts of photovoltaic energy.

The second chapter deals with the effects of the different parameters influencing the solar cells. Based on $I(v)$ curves, PV cells performance will be analyzed with the evaluation of internal as well as external parameters. In addition to that, the different electrical characteristics and modals will be presented in the beginning of the chapter for the better understanding of the $I(v)$ curves.

In the third chapter, we will present the method used, the simulation of the results and discussions.

Finally, a general conclusion crowns this thesis to summarize our analyses, results and comments.

General introduction

References:

[1] Kamaruzzaman Sopian et al, "Renewable Energy: Resources and Applications in Malaysia", Pusat Tenaga Malaysia, pp 2, ISESCO, Science and Technology Vision, volume 01 may 2005.

[2] Quaschnig, V., (2005). "Understanding Renewable Energy Systems". Earthscan Canada. 1-3.

[3] Émilie Ferreira. Cellules photovoltaïques à base d'hétérocycles pyraniques. Chimie organique. Université

Rennes 1, 2016. Français. NNT : 2016REN1S132. Tel-01578107.

[4] Cyril Aumaitre. Synthèse et études de matériaux organiques absorbeurs visible-proche infrarouge pour la réalisation de cellules solaires hybrides. Biotechnologies. Université Grenoble Alpes, 2017. Français. NNT : 2017GREAV050. tel-01900132

I CHAPTER01 : GENERALITIES



Chapter01

Chapter01

1.1 INTRODUCTION

Solar energy is the portion of the Sun's radiant heat and light, which is available at the Earth's surface for various applications of generating energy, that is, converting the energy form of the Sun into energy for useful applications. This is done, for example, by excited electrons in a photovoltaic cell, or by heating objects. This energy is free, clean, and abundant throughout the year and is important especially at the time of high fossil fuel costs and degradation of the atmosphere by the use of these fossil fuels. Solar energy is carried on the solar radiation [10]. This energy is the most dominant of all renewable energies, it is the origin of the energy sources used by man (in chemical and biochemical form in particular). Thanks to it, it is now possible to produce Electricity By using photovoltaic (PV) panels.

Initially, photovoltaic electricity was developed for stand-alone applications without connection to a power grid, mainly for the supply of isolated consumers (not connected to a grid) with an installed power ranging from a few tens to a few hundred Watts. Now; it can be found in applications of various powers. This evolution has been made possible thanks to continuous research and development over the last few years, but also through the improvement of various techniques, methods and devices.

Photovoltaic (PV) technology converts solar energy into electrical energy using semiconductors. This is the technology with the greatest potential, but also the one that requires the most of technical development. This technology is the basis for photovoltaic solar cells which have seriously started to be developed and studied since the 1950s when the first silicon-based solar cell crystalline, with a yield of 6%, was developed in Bell Laboratories.

Optimization of the performance of photovoltaic and other systems that convert sunlight into other useful forms of energy is contingent on knowledge of the properties of sunlight and photovoltaic systems. In order to best accomplish our study, we introduced this chapter with a short presentation and some generalities on solar radiation and photovoltaics. This chapter provides a synopsis of important solar phenomena, and will emphasize the characteristics of PV system.

Chapter01

I.2 INTRODUCTION TO SOLAR ENERGY

I.2.1 Solar radiation

Any discussion of solar energy and solar (photovoltaic) cells should begin with an examination of the energy source, the sun. The sun has a mass of approximately 1024 tons, a diameter of 865,000 miles, and radiates energy at a rate of some 3.8×10^{26} megawatts. Present theories predict that this output will continue, essentially unchanged, for several billion years.[9]

To maintain life in our solar system, energy is needed. The earth receives this energy from the sun, which is about 5000 [1] times the input to the Earth's energy budget from all other sources; this means that in one hour our planet obtains enough energy to meet the needs of nearly a year. In order to maximize the utilization of this important energy resource, it is advantageous to understand some of the properties of the sun.

The sun is composed of a mixture of gases with a predominance of hydrogen. The source of solar energy is the nuclear interactions at the core of the Sun. As the sun converts hydrogen to helium in a massive thermonuclear fusion reaction, mass is converted to energy according to Einstein's famous formula, $E = mc^2$. As a result of this reaction the surface of the sun is maintained at a temperature of approximately 5800 K. This energy is radiated away from the sun uniformly in all directions in close agreement with Planck's blackbody radiation formula.[2]

$$w_{\lambda} = \frac{2\pi hc^2 \lambda^{-5}}{e^{\frac{hc}{\lambda kT}} - 1} \text{ (W/m}^2\text{/unit wavelength in meters),}$$

where $h = 6.63 \times 10^{-34}$ watt sec² (Planck's constant),

$k = 1.38 \times 10^{-23}$ joules/K (Boltzmann constant).

It propagates throughout the Solar System and the Universe mainly in the form of electromagnetic radiation of which light is only the visible part.

Solar radiation is mainly composed of:

- * 48,0 % of visible light: $0,38 < \lambda \leq 0,78\mu\text{m}$;
- * 45,6 % infrared radiation (IR): $0,78 < \lambda \leq 10\mu\text{m}$;
- * Ultraviolet (UV) radiation : $0,2 < \lambda \leq 0,38\mu\text{m}$.

The maximum illumination is between 450 nm and 700 nm.

Chapter01

In fact, the atmosphere absorbs mostly the IR and UV radiation and some of the visible light. Thus, the greater the thickness of the atmosphere crossed, the weaker the amount of energy received by the ground.

The light that comes to us from the Sun is white, that is to say, it is made up of all the colors of the rainbow, each with a different wavelength.

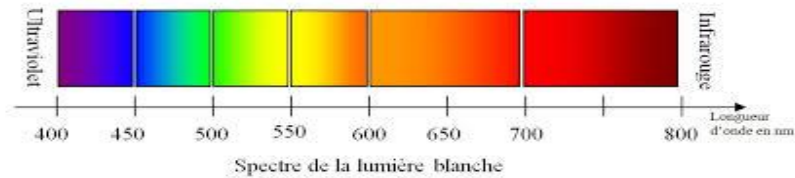

Figure 1: white light spectrum

As the radiation passes through the atmosphere, it interacts with the gaseous constituents of the atmosphere (The air that makes up the earth's atmosphere consists of an incredible number of gaseous molecules (O₂, N₂, CO₂, etc.), dust and tiny water droplets) and with all particles present in suspension (aerosols, water droplets and ice crystals), so it undergoes losses due to its partial absorption by gases and water vapor, as well as reflections from clouds and the ground.

On the other hand, this dispersion is not the same for all the wavelengths or, more simply, for the various colors of the rainbow. The dispersion is larger for the purple and blue (small wavelength) and smaller for the red (long wavelength). The blue is thus diffused, but not the red, this is why the sky is blue during the day. In the morning and in the evening, the sunlight must pass through a thicker layer of the atmosphere, about 10 times larger than at noon. The diffusion of light of short wavelength (violet and blue) is so large that the light we perceive in the sky appears red to us.

1.2.2 Variation of solar radiation as a function of the earth's movements

Detailed knowledge of the sun's position in the sky at any given moment from any point of view located on the earth makes it possible to understand and use the positioning of a solar collector (e.g. solar panel) for better conversion of solar radiation.

To locate a point M on the earth's surface, two angles are required [3] (**figure2**):

- * **Latitude φ** : the astronomical latitude is the angle that the vertical of the place makes with the equatorial plane.
- * **Longitude λ** : Longitude is the angle between the meridian of the place and the Greenwich .

Chapter01

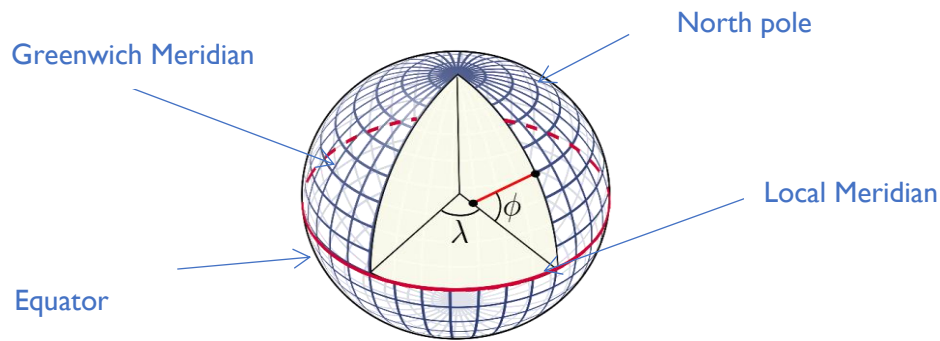

Figure 2: Longitude and latitude of a point M on the earth's surface.

On the other hand, the earth's rotation on itself in one day in 24 hours explains the succession of days and nights and its revolution around the sun in one year (365 days) explains the succession of the seasons. But seen from the earth, the sun seems to move over half a sphere(**figure3**), the center of which is the observation point on earth, doing, during the day, a circular trajectory in the sky which is none other than the reflection of the real movements of the earth.

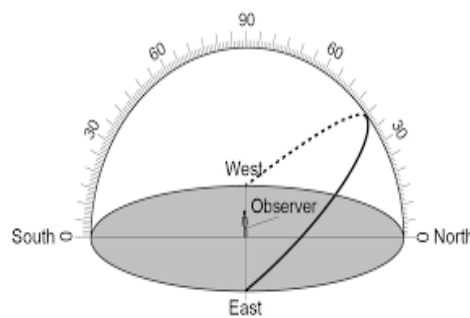

Figure 3: Seen from the earth, the sun appears to follow a circular path around an axis of apparent rotation passing approximately through the North Pole Star. Same thing happens to the stars by night. The only star that is motionless is the North Star.

Over the course of the year, the (apparent) trajectory that the sun takes in the sky changes every day (**Figure4**) it rises more or less high in the sky; it rises and sets in different places and the day lasts more or less long, but all these trajectories are parallel to each other and perpendicular to the axis of the earth's apparent rotation. This axis of rotation is in the direction of the Pole Star: the only star standing still among all the revolving stars and pointing north.

Chapter01

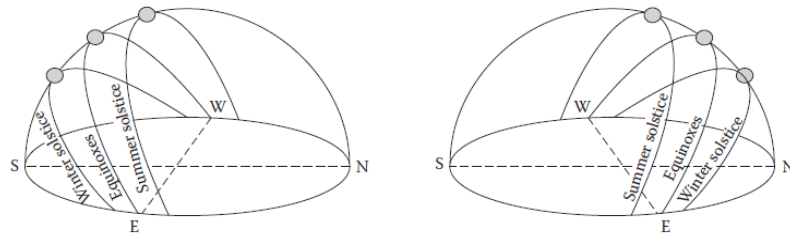

Figure 4: Apparent daily path of the Sun in the sky throughout the year for an observer in the Northern (left) and Southern Hemispheres (right).

The day of the **equinoxes** of spring and autumn, the sun describes the celestial equator. These are the only two days of the year when the sun rises exactly east and sets exactly west and where day and night are of equal length of twelve (12) hours. In this case, the area travelled by the sun is 180° .

On the day of the **summer solstice**, the sun reaches its highest point in the sky; it rises in the northeast and sets in the northwest and the sector travelled by the sun is 240° .

The day of the **winter solstice** is the time when the sun stays the longest down. It rises in the southeast and sets in the southwest with a covered area equal to 120° .

This change in the apparent trajectory (seen from the earth) of the sun during the year is due to the fact that the axis of rotation (the direction of which does not change) of the earth on itself is not perpendicular to the plane of the ecliptic (the plane of revolution of the earth containing the sun) but is inclined with respect to the ecliptic perpendicular by an angle equal to $23,43^\circ$ (**Figure5**) [4]

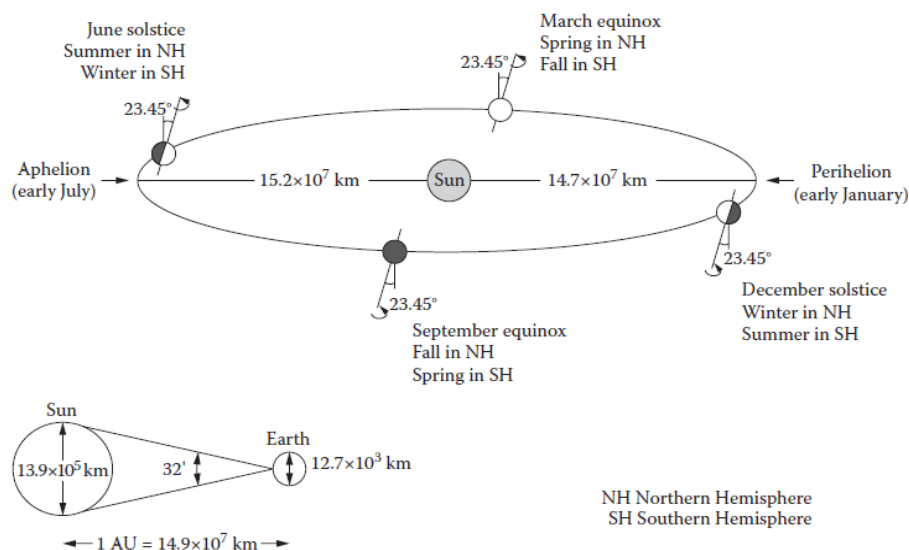

Figure 5: Four (04) remarkable positions of the earth in relation to the sun. The axis of rotation of the earth is inclined with respect to the vertical to the ecliptic plane at an angle $23, 43^\circ$. This results in declinations of the sun-earth direction.

Chapter 01

For this purpose, a graphical representation of the sun's path called the solar diagram is used, which is none other than an earthly view of the sun's movement. Thus, the position of the sun in the sky is referenced to an observer in the horizontal plane using two coordinates:

height and azimuth,

The **height** of the sun is the angle between the direction of the sun and the earth (observer) with the horizontal plane.

The (geographic) **azimuth** is the angle that the projection of the direction of the sun-earth (observer) on the horizontal plane with the direction North-observer.

In order to plot the solar diagram, all the heights and azimuths of the sun during these daily trajectories over a year from the same observation point are taken. These measurements will be reported on a system of two axes: the heights on the vertical axis going from 0 (for the horizon) towards 90 (for the zenith) and azimuths on the horizontal axis. Therefore, the position of the sun at a given moment in the sky is represented by a point that is the intersection of two straight lines, one of which is the vertical representing the height of the sun and the other horizontal representing its azimuth. By locating the sun at different times of the day, we obtain the path of the sun.

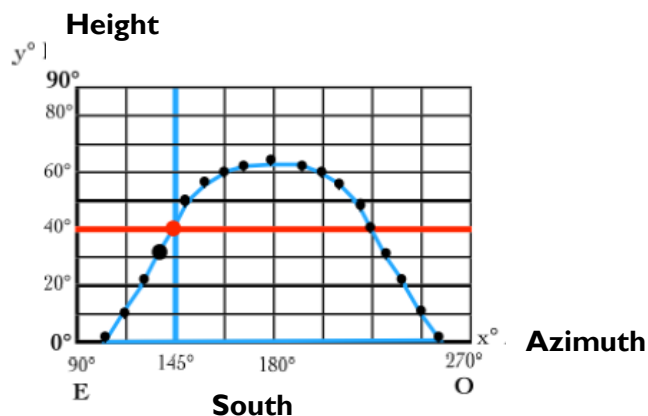

Figure 6: On a solar diagram, the heights are plotted on the vertical axis and the azimuths are plotted on the axis horizontal. The position of the sun in the sky at a given moment is represented by a point on the plane.

1.2.3 Solar spectral distribution

The solar radiation that arrives on the ground is divided into three parts: a direct part that comes directly from the sun, a second part diffused by the atmosphere, and the other part reflected.

The atmosphere and the earth also have their own radiation. The knowledge of these various radiations allows us to establish a radiation balance of the earth-atmosphere system.

Chapter 01

- * **Direct radiation** is received directly from the sun, without scattering by the atmosphere. Its rays are parallel to each other, so it forms shadows and can be concentrated by mirrors.
- * **Scattered radiation** consists of photons scattered by fine particles or molecules of different sizes in the atmosphere (air, cloud cover, aerosols). That is to say, reflected in all directions.
- * **The albedo** is the part reflected by the ground. Because in reality the earth is not a black body, it depends on the environment of the earth's surface, it will have to be taken into account to evaluate the radiation on inclined planes.

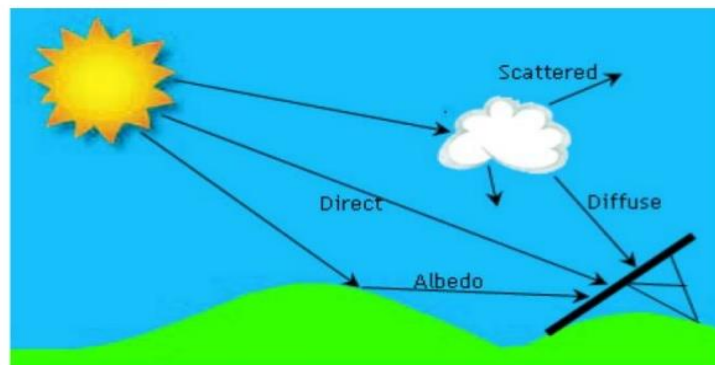

Figure 7: Components of solar radiation

1.3 MEASURING SUNLIGHT

The electromagnetic radiation from the sun (including gamma rays, X-rays, Ultra-Violet, visible, Infra-Red, microwaves and radio waves) can be described in terms of electromagnetic wave characterized by a frequency ν and a wavelength λ , and also of photons, moving at speed of light ($c= 3.108 \text{ m. s}^{-1}$). The energy of this particle is given by the Planck-Einstein relation:

$$E = h \nu = \frac{hc}{\lambda}$$

With the Planck's constant $h= 6.6 \times 10^{-34} \text{ J.s}$

However, not all of the electromagnetic radiation reaches the Earth's surface, the solar spectrum at Earth's surface is therefore dependent of many atmospheric parameters as seen previously as well as the path length through the atmosphere.

It is characterized by an Air-Mass coefficient, "AM X", and defined as the optical path length L through Earth's atmosphere, commonly used for terrestrial applications such photovoltaic solar cells.

When the Sun is directly at its zenith the Air-Mass indicator is denoted AM 1, "1" for one atmosphere with a solar irradiance at Earth's surface (at sea level more precisely) reaching 1040 W/m^2 in optimum conditions. This value is further reduced compared to the extraterrestrial solar radiation referred as air mass zero, AM 0, meaning no atmosphere.

Chapter01

For incident solar radiation at angle θ relative to the normal to the Earth's surface L_0 , the Air-Mass coefficient is expressed as:

$$AM X = \frac{L}{L_0} = \frac{1}{\cos \theta}$$

1.3.1 The pyranometer

Since all the calculations and approximations in the world cannot yield exact predictions of the amount of sunlight that will fall on a given surface at a given angle at a given time at a given day in a given place, the design of photovoltaic power systems is dependent upon the use of data based on measurements averaged over a long time. The **pyranometer** is designed to measure global radiation. It is a heat flow sensor used to measure the amount of solar energy in natural light. The pyranometer is designed to respond to all wavelengths and, hence, it responds accurately to the total power in any incident spectrum.[2]

Many inexpensive instruments are also available for measuring light intensity, including instruments based on cadmium sulfide photocells and silicon photodiodes. These devices give good indications of relative intensity, but are not sensitive to the total solar spectrum and thus cannot be accurately calibrated to measure total energy. These devices also do not normally have lenses that capture incident radiation from all directions.[5]



Figure 8: Pyranometer for Measuring the irradiance of a Solar Farm, in a Solar Cell Factory

1.4 SURFACE PROPERTY

When radiated photons or electromagnetic waves reach another surface, they may be absorbed, reflected, or transmitted. From an energy stand point, the sum of the absorbed, reflected, and transmitted fraction of radiation energy must be equal to unity:

$$\alpha + \rho + \tau = 1$$

where

α is absorptivity (fraction of incident radiation that is absorbed)

Chapter 01

ρ is reflectivity (fraction of incident radiation that is reflected)

τ is transmissivity (fraction of incident radiation that is transmitted)

1.4.1 Black body radiation

Another key concept for solar energy is blackbody radiation. A blackbody is an ideal thermal radiator. It absorbs all incident radiation, regardless of wavelength and direction (absorptivity=1), it also emits maximum radiation energy in all directions (diffuse emitter). The emitted energy by a blackbody (blackbody emissive power, W/m²) is given by the Stefan–Boltzmann law (Incropera and DeWitt):

$$E = \sigma T^4$$

where σ is the Stefan–Boltzmann constant ($\sigma = 5.67 \times 10^{-8} \text{ W/m}^2\text{K}^4$) and T is the absolute temperature.

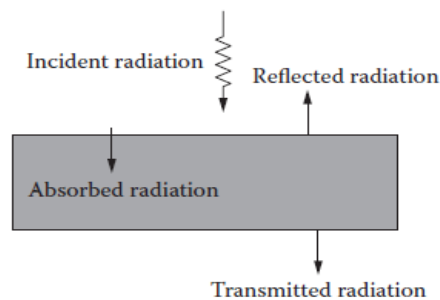

Figure 9: Radiation surface properties

1.5 PHOTOVOLTAIC CELLS

1.5.1 Photovoltaic effect and the p-n junction

the photoelectric or photovoltaic effect, discovered in 1839 by Antoine Becquerel and then highlighted by Heinrich Hertz in 1887 is defined as the process that allows the creation of moving electrons or holes (electron defects) in a material that absorbs the photons that illuminate it and constitutes the basic principle of photovoltaic cells [11]. Most inorganic PV cells are based on p-n junctions. The latter results from the combination of a p-type semiconductor (majority holes) and an n-type semiconductor (majority electrons). After contacting, the holes of the p semiconductor diffuse towards the n semiconductor and vice versa for the electrons of the n semiconductor. A zone free of charge carriers then appears in the central area of the junction called the space charge zone (SZC). This is formed by fixed ions resulting from doping, and thus creates an internal electric field which opposes the diffusion of the majority carriers. After the junction is established, the photocarriers created in the neutral regions, which are free of electric field, generate diffusion currents, while those created in the Width Space Charge Zone, WZCE, are accelerated by the electric field towards the areas where they become majority carriers. Therefore, only the excess minority carriers are active in a p-n junction and participate in the generation of a current (sum of diffusion and drift currents).

Chapter 01

1.5.2 Energy band gap

When light shines on a material, it is either reflected, transmitted, or absorbed. Absorption of light is the conversion of the energy contained in the light to another form of energy, typically heat. Some materials, however, happen to have just the right properties needed to convert the energy in the incident photons to electrical energy. When a photon is absorbed, it interacts with an atom in the absorbing material by giving off its energy to an electron in the material. This energy transfer is governed by the rules of conservation of momentum and conservation of energy. Since the zero-mass photon has very small momentum compared to the electrons and holes, the transfer of energy from a photon to a material occurs with inconsequential momentum transfer. Depending on the energy of the photon, an electron may be raised to a higher energy state within an atom or it may be liberated from the atom. Liberated electrons are then capable of moving through the crystal in accordance with whatever phenomena may be present that could cause the electron to move, such as temperature, diffusion or an electric field.

Semiconductor materials are characterized as being perfect insulators at absolute zero temperature, with charge carriers being made available for conduction as the temperature of the material is increased. This phenomenon can be explained on the basis of quantum theory, by noting that semiconductor materials have an energy band gap between the valence band and the conduction band. The valence band represents the allowable energies of valence electrons that are bound to host atoms. The conduction band represents the allowable energies of electrons that have received energy from some mechanism and are now no longer bound to specific host atoms. At $T = 0$ K, all allowable energy states in the valence band of a semiconductor are occupied by electrons, and no allowable energy states in the conduction band are occupied. Since the conduction process requires that charge carriers move from one state to another within an energy band, no conduction can take place when all states are occupied or when all states are empty. This is illustrated in Figure 10.a. As temperature of a semiconductor sample is increased, sufficient energy is imparted to a small fraction of the electrons in the valence band for them to move to the conduction band. In effect, these electrons are leaving covalent bonds in the semiconductor host material. When an electron leaves the valence band, an opening is left which may now be occupied by another electron, provided that the other electron moves to the opening. If this happens, of course, the electron that moves in the valence band to the opening, leaves behind an opening in the location from which it moved. If one engages in an elegant quantum mechanical explanation of this phenomenon, it must be concluded that the electron moving in the valence band must have either a negative effective mass along with its negative charge, or, alternatively, a positive effective mass and a positive charge. The latter has been the popular description, and, as a result, the electron motion in the valence band is called hole motion, where “hole” is

Chapter01

the name chosen for the positive charges, since they relate to the moving holes that the electrons have left in the valence band. What is important to note about these conduction electrons and valence holes is that they have occurred in pairs. Hence, when an electron is moved from the valence band to the conduction band in a semiconductor by whatever means, it constitutes the creation of an electron-hole pair (EHP). Both charge carriers are then free to become a part of the conduction process in the material.[12]

1.5.3 Doping

In order to change the electronic properties of a semiconductor material, we use Doping, which is the purposeful introduction of impurities into a semiconductor by controlling the number of electrons in the conduction band. Impurity atoms can be introduced into a material in two ways. They may be squeezed into the interstitial spaces between the atoms of the host crystal (called interstitial impurities) or they may substitute for an atom of the host crystal while maintaining the regular crystalline atomic structure (substitutional impurities). Note that a much smaller amount of energy is required to release an electron as compared to the energy needed to release one in a covalent bond. The energy level of this fifth electron corresponds to an isolated energy level lying in the forbidden gap region. This level can be called a donor level and the impurity atom responsible is called a donor. A concentration of donors can increase the conductivity so drastically that conduction due to impurities becomes the dominant conductance mechanism. In this case, the conductivity is due almost entirely to negative charge (electron) motion and the material is called an n-type semiconductor. Similarly, when a group of impurity (boron) is introduced, there are only three valence electrons and the material have an affinity to attract electrons from the material, thus leaving a hole. Hole movements collectively create an energy level in the forbidden gap close to the valence band. This level can be called an acceptor level and the impurity atom responsible is called an acceptor. The material is called a p-type positive semiconductor with p-type impurities.[13]

1.6 PHYSICAL CHARACTERIZATION OF PHOTOVOLTAIC CELLS [14]

1.6.1 Current/voltage characteristic and equivalent circuit

The **figure10** represents a current-voltage characteristic of a photovoltaic cell. According to the usual sign convention, the photocurrent in an ideal solar cell can be assimilated to a current source directed in the opposite direction of the diode characteristic in the dark, as shown in diagram c of **figure10**.

Chapter01

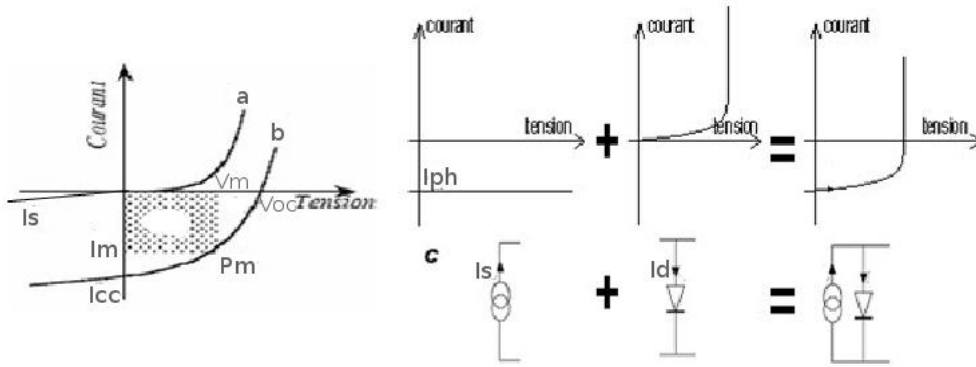

Figure 10: Current/voltage characteristic of a PV cell: a) dark, b) under illumination, c) equivalent diagram of an ideal solar cell under illumination.

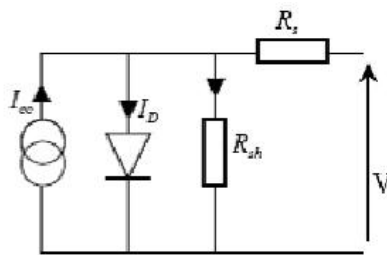

Figure 11: Equivalent circuit of a solar cell

For an unlit solar cell polarized by a voltage V , the curve obeys the following Shockly equation:

$$I = I_s \left[\exp\left(\frac{qV}{nKT}\right) - 1 \right] \quad (1.1)$$

where I is the saturation current, q is the electron charge, k is the Boltzmann constant, T is the temperature and n is the ideality factor of the diode which takes into account recombination (in the ideal case it is equal to 1).

Under illumination, an additional inverse current I_{ph} is added (taking into account the photocurrent)

$$I = I_s \left[\exp\left(\frac{qV}{nKT}\right) - 1 \right] - I_{ph} \quad (1.2)$$

It is clear from **Figure10** that in total darkness, characteristic $I(V)$ passes through the origin, whereas this is not the case in the presence of light radiation.

In the real case, contact resistances (resistivity of the electrodes and organic metal-material interfaces) and ohmic losses (due to the resistivity of the organic layers) as well as leakage currents (short-circuit currents) occur through the cell.

Figure11 shows the equivalent circuit of a real PV cell. R_s is a series resistance related to the volume resistivity and impedance of the electrodes and materials. It represents the inverse of the slope of the

Chapter01

current-voltage curve at the point **Vco**. **Rsh** is a shunt resistor related to edge and volume recombination. It represents the inverse of the slope of the current-voltage curve at the point **Icc**. These resistors give in the real case an evaluation of the imperfections of the diode, and in general, the value of **Rsh** is greater than **Rs** ($Rsh \gg Rs$). The ideal case is represented by: $Rsh \rightarrow \infty$ and $Rs=0$.

1.6.2 Photovoltaic cell parameters [15]

The parameters of the photovoltaic cells (I_{cc} , V_{co} , FF and η), extracted from the current-voltage characteristics, allow to compare different cells illuminated under identical conditions. These parameters are defined as follows:

1.6.2.1 Short circuit current I_{cc}

The short-circuit current I_{cc} is the current that flows through the junction under illumination without voltage application. It increases with the illumination intensity of the cell and depends on the illuminated surface, the wavelength of the radiation, the mobility of the carriers and the temperature.

1.6.2.2 Open circuit voltage V_{co}

The open circuit voltage V_{co} is the voltage measured when no current is flowing through the photovoltaic device. It depends mainly on the type of solar cell (pn junction, Schottky junction), the materials of the active layer and the nature of the active layer-electrode contacts. In addition, it depends on the illumination of the cell. we can easily get the expression of V_{co} in the case of a null current from the expression:

$$V_{co} = \frac{KT}{q} \ln \left(\frac{I_{ph}}{I_s} + 1 \right) \quad (1.3)$$

Two regimes can be observed depending on the degree of illumination (**Figure12**):

In this case, $I_{ph} \ll I_s$,

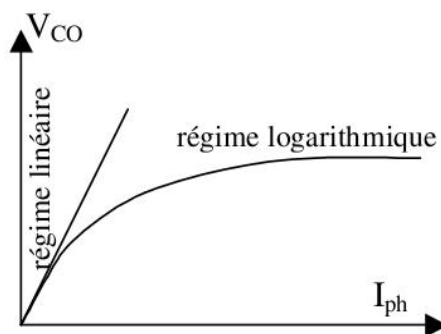

Figure 12: Different speeds according to illumination power

Chapter01

1.6.2.3 Fill Factor

The power supplied to the external circuit by a photovoltaic cell under illumination depends on the load resistance. This power is maximum (noted P_{max}) for an operating point P_m ($I_m \cdot V_m$) of the current-voltage curve (current between 0 and I_{cc} and voltage between 0 and V_{co})

The fill factor or form factor FF can be denoted by the following expression:

$$FF = \frac{P_{max}}{V_{co} I_{cc}} = \frac{I_m V_m}{V_{co} I_{cc}} \quad (1.4)$$

1.6.2.4 Efficiency η

It represents the external energy efficiency of power conversion, values that affect the efficiency of solar cells are the band gap of the semiconductor, operating temperature, incident light, type and purity of the material, and parasitic resistances. It is defined by the following expression:

$$\eta = \frac{P_{max}}{P_{in}} = \frac{FF I_{cc} V_{co}}{P_{in}} \quad (1.5)$$

P_{in} represents the incident light power.

This efficiency can be optimized by increasing the form factor, short-circuit current and open circuit voltage. This is an essential parameter, as only knowing its value allows the performance of the cell to be evaluated.

1.7 MAIN TYPES OF SOLAR CELLS

1.7.1 Inorganic photovoltaic cells

At present, the photovoltaic cells with the best photoconversion efficiency are based on the use of inorganic materials. Several types can be distinguished:

1.7.1.1 Silicon-based cells

Silicon is obtained from one or more crystals. Within this family, several types of cells using different qualities of silicon can be distinguished: mono-crystalline Si-based cells (efficiency of around 25%, high manufacturing cost), polycrystalline Si-based cells (efficiency of around 20%, lower manufacturing cost) and amorphous Si-based cells (lower efficiency and cost less than mono or polycrystalline).

1.7.1.2 Monocrystalline silicon cells [16]

Monocrystalline silicon cells offer the highest efficiency among commercially available solar panels: between 15 and 25%. These cells are made up of very pure crystals obtained by a strict and progressive control of the cooling of the silicon.

Chapter01



Figure 13: Monocrystalline silicon cell

1.7.1.3 Polycrystalline silicon cells (or multicrystalline)

Modules using polycrystalline silicon cells generally have an efficiency of between 10 and 14%. These cells are simpler to manufacture and cheaper than monocrystalline silicon cells. Polycrystalline cells are recognizable by the irregular shapes of the crystals that are clearly visible to the human eye.

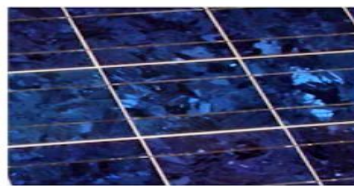

Figure 14: Monocrystalline silicon cell

1.7.1.4 Amorphous silicon cells

Amorphous silicon cells are thin-film cells between 10 μm to 100-200 μm . they are manufactured by depositing a thin layer of silicon on a support (or "substrate"), (steel, glass, plastic ... etc.).



Figure 15: Amorphous silicon cells

This technology reduces the manufacturing cost, but its efficiency is lower than that of crystalline silicon cells (around 5 to 8%), and is therefore reserved for applications requiring low power.

1.7.1.5 Gallium arsenide based cells

A distinction must be made between two types of cells incorporating gallium arsenide. On the one hand, type III.V cells whose main component is gallium arsenide (yield of the order of 18 to 25%). On the other hand, multijunction cells (GInP/GaAs/Ge type) (efficiency of about 32%) but have a very high shaping cost.

Chapter 01

1.7.1.6 CIS or CIGS cells

The former is composed of copper indium diselenide (CuInSe_2), while the latter also include gallium. This type of cell has a low manufacturing cost.

1.7.1.7 Cadmium telluride (CdTe) cells

The advantage of these cells lies in the high absorption of cadmium telluride; however, the toxicity of the material hinders the development of this technology. The yields obtained are of the order of 17%.

1.7.2 Organic photovoltaic cells

In the face of technology using inorganic materials, solar cells based on organic compounds are undergoing considerable development. Organic cells can be of several types:

1.7.2.1 Schottky type cells

This type of cell uses a p (or n) type semiconductor taken between two metal electrodes. The active area for photovoltaic conversion is between one of the metal electrodes and the semiconductor.

1.7.2.2 Heterojunction cells of the bilayer type

Two semiconductors, one p-type and the other n-type, are in contact forming a p-n junction. The active area is the interface between the two semiconductors.

1.7.2.3 Interpenetrating network type heterojunction cells

In this type of cell, p and n semiconductors are intimately mixed within a single layer. The contact area between the p and n semiconductors is multiplied by several orders of magnitude in comparison to bilayer cells, which increases the number of dissociated excitons

1.7.2.4 Hybrid dye sensitized cells [17]

Dye sensitized solar cells or Gratzel solar cells are photoelectrochemical cells. A basic type of electrochemical cell does not include a p-n or other junction between two solid inorganic semiconductors, but is composed of semiconductor electrode, an electrolyte layer and counter electrode, covered with Pt. The basis for both electrodes is the transparent TCO glass. TCO is short for transparent conductive oxides. Photoelectrochemical cell converts light to electric power with no net chemical change behind. At the interface between semiconductor and electrolyte, a space charge layer is formed, depending on the type of both semiconductor and electrolyte. In equilibrium, the chemical potential of electrons in the solid state is equal to the redox potential of the electrolyte Redox. Photons exceeding the band gap energy produce electron-hole pairs that are separated by electric field in the space charge layer. The electrons diffuse to the end of electrode and are transported through the external circuit with resistance. The holes are driven to the electrolyte interface, where they oxidize a molecule of redox pair. The oxidized molecule is reduced again by an electron that re-enters the cell through the external circuit.

Chapter01

1.8 PHOTOVOLTAIC CONVERSION SYSTEM

A photovoltaic solar power plant is formed by a set of solar panels, connected to each other in series or parallel and connected to a or multiple inverters. These are used to transform the low-voltage DC current into high-voltage alternating current, directly usable by conventional devices.

However, the amount of energy obtained depends on a number of factors, namely, the surface area of the modules used, as well as their efficiency and the amount of sunlight that varies with latitude, season and weather.

A photovoltaic system is composed of several tools necessary to ensure an optimal electricity production. Any photovoltaic system can be composed of three parts:

- One part of power generation.
- One part for the conversion of the energy generated.
- One part of energy storage.

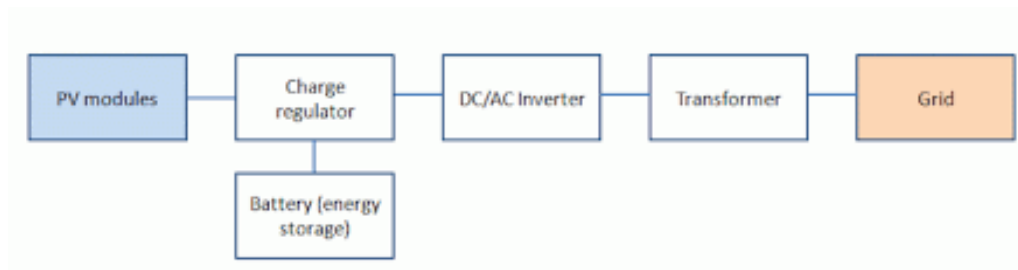

Figure 16: Typical energy transformation path in a grid connected PV system

These components depend on the type of the photovoltaic system. There are two types of systems:

1.8.1 STAND ALONE / OFF GRID

This type of installation is suitable for installations that cannot be connected to the network. Neither the building nor the panel are connected. The energy produced must be directly consumed and/or stored in accumulators to ensure that all requirements can be met.

These installations usually contain a **photovoltaic panel** to produce direct current, a **regulator** to protect the battery, an **inverter** that converts direct current into alternating current, and **batteries** that are charged during the day to provide power at night.

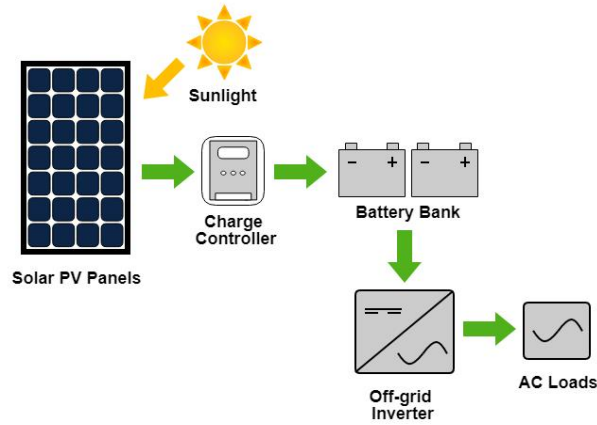

Figure 17: example of an off grid photovoltaic system

1.8.2 GRID CONNECTED

The photovoltaic system works as in isolated installations, but is connected directly to the public grid.

A grid-connected photovoltaic system consists of the following components:

- **Photovoltaic generator:** which should be exposed as much as possible in order to collect the maximum amount of sunlight over the year.
- **An inverter:** its role is to transform the direct current supplied by the photovoltaic generator into an alternating current having all the characteristics of the alternating current supplied by the electrical grid.
- **Safety and grid connection devices:** which ensure the protection of people and property.
- **A means of storing electricity:** possibly composed of batteries (lithium-ion, etc...).

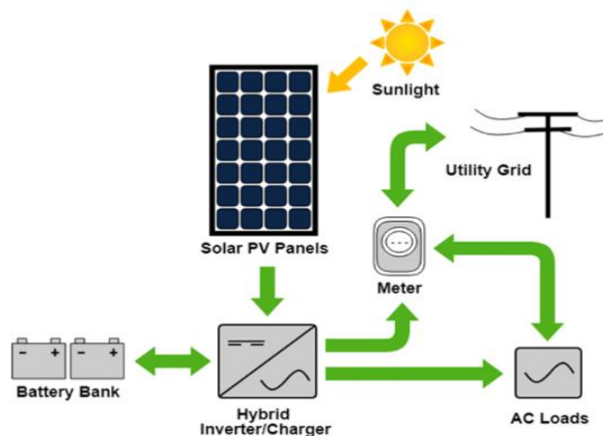

Figure 18: example of a grid connected system

Chapter01

1.8.3 power generation

Energy production is achieved by converting solar energy into electricity, this part is essentially composed of one or more modules.

The photovoltaic panel consists of small cells that produce a very low electrical power (1 to 3 W) [6]. These cells are arranged in series to form a module or panel to produce higher power. The panels are finally interconnected with each other (in series and/or in parallel) to obtain a photovoltaic field.

1.8.4 Control system (regulation system)

In nearly all systems with battery storage, a charge controller is an essential component. The charge regulator has two main functions:

- protection of the batteries against overcharging and deep discharge.
- optimizing the energy transfer from the PV field to the application.

All photovoltaic systems must include careful regulation of battery charging and discharging, this is because the battery is one of the most fragile components of a PV system; its lifetime is closely related to the way it is charged and discharged.

The charge controller must shut down the load when the battery reaches a prescribed state of discharge and must shut down the PV array when the battery is fully charged (current reduction when the battery is almost fully charged, because when the current is too high a deformation of the electrodes inside can be caused, which could create a short circuit[6]).

When the “battery” is really a system of batteries connected in series and parallel as needed to meet system needs, the control process becomes somewhat of a challenge. The controller should be adjustable to ensure optimal battery system performance under various charging, discharging and temperature conditions.

there are several types of regulators:

1.8.4.1 Shunt regulator

Suitable for small power applications with 1 or 2 PV modules. The shunt regulator controls the battery charge by safely short-circuiting the PV module. All shunt controllers require a non-return diode in series between the battery and the shunt element to prevent the battery from short-circuiting.

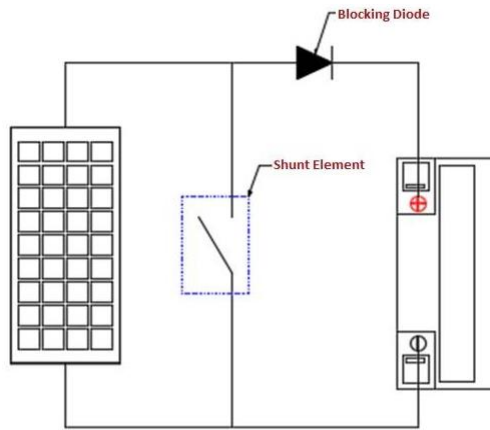

Figure 19: PV system including shunt charge regulator

1.8.4.2 Serial Regulator

Suitable for medium power applications with PV module currents above 10 A [6]. When the battery reaches full charge, the controller shuts off the current from the PV modules.

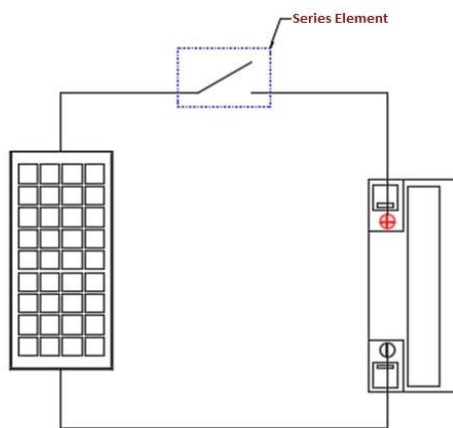

Figure 20: PV system including series charge regulator

1.8.4.3 MPPT controller

Suitable for high power applications. Ensures maximum power recovery from PV modules by continuously measuring current and voltage.

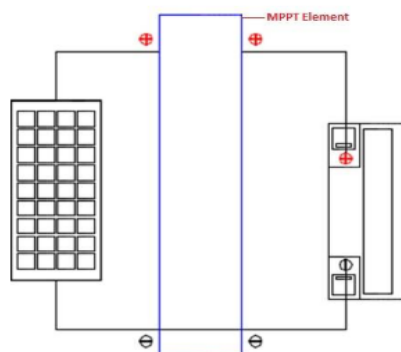

Figure 21: PV system including MPPT controller

Chapter01

1.8.5 Converter system

The energy conversion system is usually located either between the PV field and the load (without storage with DC charging, DC-DC converter) or between the battery and the load (in this case it will be called inverter or DC-AC converter).

1.8.5.1 The DC-DC converter

This type of converter is designed to adapt at any time the apparent impedance of the load to the impedance of the PV field corresponding to the point of maximum power. This matching system is commonly called MPPT (maximum power point tracking). Its efficiency is between 90 and 95% [6].

1.8.5.2 The DC-AC converter

In order to supply devices that operate on alternating current, a converter must be interposed between the battery and these devices. The most commonly used converters convert the direct current from the battery into 220 V/50 Hz or 380 V/50 Hz alternating current. [7]

1.8.6 Energy storage

In intermittent power generation systems, particularly photovoltaic systems, it is essential to be able to store energy in order to adjust production to consumption. This is particularly true for systems which are not connected to a power grid, even when the electrical grid is present, the use of storage makes it possible to smooth intermittent production and inject energy during the most relevant periods (night and "sunless" days).

The storage system is a crucial part of the photovoltaic installation from a technical point of view, but also from an economic point of view, as it accounts for 40-50% [6] of the cost of the installation.

1.9 ECONOMICS

1.9.1 solar energy is free, but what does it cost?

Solar energy is free, but this doesn't make it cheap. Over the past few decades, solar products had known a remarkable cost reduction, thus, small- and medium-scale uses home applications are still relatively expensive [18]. Having a home designed to use solar power won't cost more than a regular home, even much less operating costs. The basic difference between them is that the solar-energy house is fed by the sun, it needs smaller systems that cool/ heat it, while poorly designed homes fight the Sun and are very cold in winter and extremely hot in summer [19]. Industrial and modern agriculture societies were founded on fossil fuels (coal, oil, and gas). As energy demand increases due to developing countries modernization, increased fuel prices will force alternatives to be introduced. The world will make a gradual shift throughout the twenty-first century technologies that harness clean energy sources such as sun and wind [18]. As the full effect and impact of environmental

Chapter 01

externalities such as global warming become apparent, society will demand cleaner energy technologies and policies that favor development of a clean-energy industrial base. The cost of technologically driven approaches for clean energy will continue to fall and become more competitive. Eventually, clean energy technologies will be the inexpensive solution. By the end of the twenty-first century, clean-energy sources will dominate. This will not be an easy or cheap transition for society, but it is necessary. Already, solar energy is cost effective for many urban and rural applications. Solar hot-water systems are very competitive, with typical paybacks from 5–7 years as compared to electric hot water heaters (depending on the local solar resource). For sites that are remote from the electric grid, PV systems are already cost competitive, although they are also popular for on-grid applications as environmental “elitists” try to demonstrate that they are “green”. However, installing grid-tied PV systems without making efforts to install energy-efficient equipment first for people and companies working in the field of “green-washing” should be aware of their efficiency. The solar energy usage is not only for reducing carbon emissions, far more can be achieved through that energy conservation. The decision to use a solar energy system over conventional technologies depends on the energy security, economic, and environmental benefits expected. It is fact that the investment cost in Solar energy systems; but in the other hand, they do not require fuel and often require little maintenance. The traditional business entities have always couched their concerns in terms of economics, judging that a clean environment is uneconomical or that renewable energy is too expensive. Due to the lack of maintenance and long-term life cycle costs of a solar energy system should be understood to determine whether such a system is economically viable. [20]

1.9.2 Cost of Energy [21]

The cost of energy (COE) is primarily driven by the installed cost and the annual energy production. For PV systems, that cost is determined primarily by the cost of the modules. For on-grid systems, PV costs are from about \$6–\$8/Wp. After losses, each Watt produces 2–6 Wh/day, depending on solar resource; this translates to about \$0.22–\$0.35/kWh. The cost of remote stand-alone PV systems with batteries will be from 1.5–2 times more than grid-connected systems. High-quality industrial batteries last 7–9 years; others last 3–5 years.

1.9.3 PV cost [22]

For many applications, especially remote-site and small-power applications, PV power is the most cost-effective option available. Generating clean electric power on site without using fossil fuel is an added benefit. Capital costs are high for PV, but fuel costs are nonexistent. PV module costs have dropped by an order of magnitude over the past two decades. New PV modules generally cost about \$3 per Watt, depending on quantities purchased. Off-grid PV systems with battery storage typically

Chapter01

run from about \$12 to \$15 per peak Watt installed, depending on system size and location. Grid-tie PV systems are averaging \$6–\$8 per Watt installed, also depending on system size and location.

Larger PV water pumping systems with all balance-of-system components, including the pump, can be installed for under \$10 per Watt. A well-designed PV system requires minimal maintenance, which leads to significant labor and travel savings. PV modules on the market today are guaranteed for about 25 years and quality crystalline PV modules should last over 50 years. It is important when designing PV systems to be realistic and flexible and not to overdesign the system or overestimate energy requirements. PV conversion efficiencies and manufacturing processes will continue to improve, causing prices gradually to decrease. It takes many years to bring PV cells from the laboratory into commercial production, so overnight breakthroughs in the marketplace should not be expected.

1.9.4 Life cycle cost [23]

In order to gain a true perspective of the economic value of solar energy systems, it is necessary to compare solar technologies to conventional energy technologies on a life cycle cost (LCC) basis. This method permits the calculation of total system cost during a determined period of time, considering not only initial investment but also costs incurred during the functioning time of the system. The LCC is the “present value” life cycle cost of the initial investment cost, as well as long-term costs directly related to repair, operation, maintenance, transportation to the site, and fuel used to run the system. Present value is understood as the calculation of expenses that will be realized in the future but applied in the present. A LCC analysis can determine the total cost of the whole system, including all expenses incurred over the functioning time of the system. The main reasons to do this LCC analysis are comparing different options of power technology, and determining which one has the most cost-effective system designs. For some renewable energy applications, there are not any options to small renewable energy systems because they produce power where there is no power. For these applications, the first estimated cost of the system, the infrastructure needed to start using the system and maintaining its good performances, and the price people pay for the energy are the main concerns. An LCC analysis permit studying the effect of using different components with different reliabilities and lifetimes. For instance, a less expensive battery might be expected to last 4 years, while a more expensive battery might last 7 years. Which battery is the best to buy? This type of question can be answered with an LCC analysis:

$$\mathbf{LCC=C+Mp_w+E_p_w+R_p_w-S_p_w}$$

Chapter 01

where

LCC = life cycle cost.

C = initial cost of installation minus (-) the actual value of the cost equipment, including system design, engineering, and installation additional cost.

Mpw = sum of all operation and maintenance yearly costs minus (-) the present value of expenses due to operation and maintenance programs.

Epw = the cost of energy, sum of fuel costs of all years minus (-) the cost of fuel consumed by the conventional pumping equipment.

Rpw = sum of replacement costs of all years minus (-) the actual cost of replacement components anticipated over the operating time of the system.

Spw = salvage value minus (-) net worth at end of final year.

Future costs must be discounted because of the changes that may occur on the money's value over time, so the present worth is calculated for costs for each year. Life span for PV is assumed to be 20–25 years. Life cycle costing is the best way of purchasing decisions. On this basis, many renewable energy systems are economical. The financial evaluation can be done on a yearly basis to obtain cash flow, breakeven point, and payback time.

1.10 PHOTOVOLTAIC APPLICATIONS

Solar cell technologies are used for two main applications, namely space and terrestrial applications. The PV solar systems are already an important part of our lives. The simplest PV solar systems power are in many of the small calculators and wrist watches that we use every day. More complicated systems provide electricity for pumping water, powering communications equipment, and even lighting our homes and running our household appliances. At present, there are four primary market areas for photovoltaic terrestrial applications:

- Consumer products, such as watches, calculators, and lanterns.
- Off-grid, power systems, such as solar home systems for individual households.
- Off-grid industrial power systems for water management, lighting, and telecommunication.
- Grid connected PV systems that are integrated in roofs and outer walls of buildings or in noise barriers along the motorways.

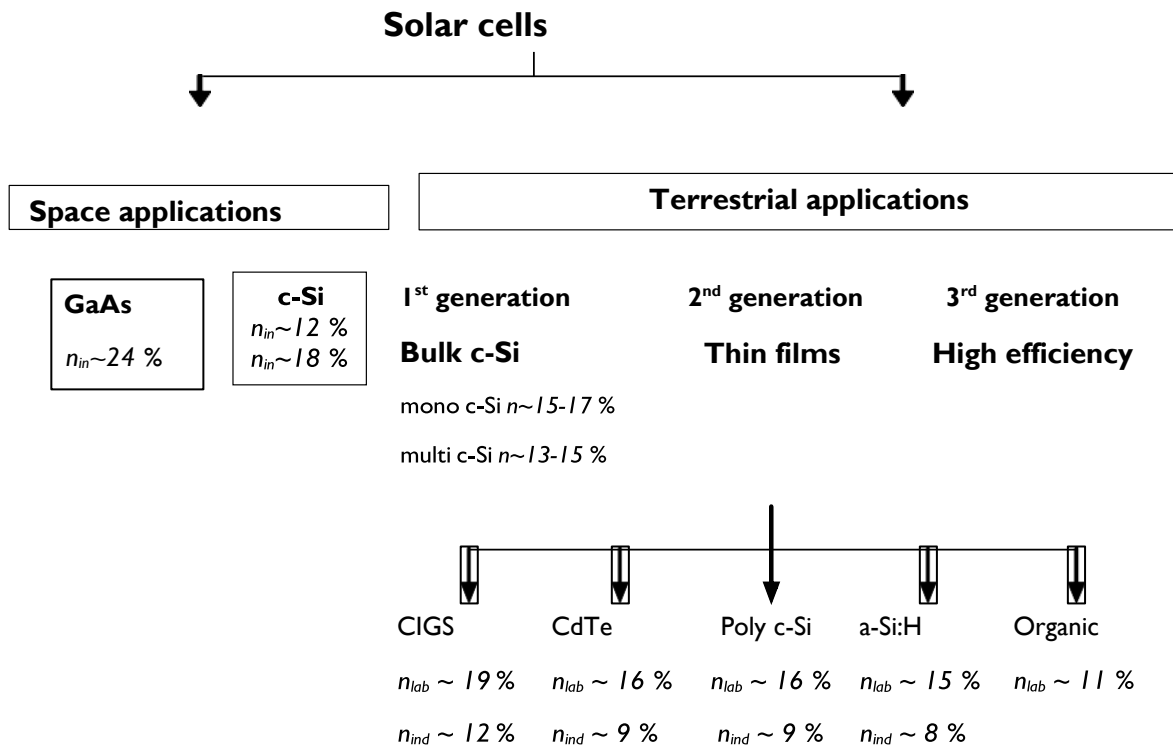

Figure 22: Overview of solar cell applications and of several types of solar cells used in different applications.

1.1.1 ENVIRONMENTAL IMPACT

Electrical energy is the axis of all growth efforts in both the developed and the developing nations because conventional energy sources are finite and fast depleting. In the last decades, energy related problems are turning into major issues and involve the ideal use of resources, the environmental impact due to the emission of pollutants and the consumption of conventional energy resources.

Using solar energy can have a positive effect on the environment when solar energy replaces the use of other energies that have larger effects on the environment. Solar energy systems do not produce air pollution, water pollution, or greenhouse gases. PV modules generate electricity directly from light without emissions, noise, or vibration. But large solar power plants can affect the environment.

Solar energy has low energy density: PV modules require a **large surface area** for small amounts of energy generation. Near their locations, clearing land for construction and the placement of the power plant may have long-term effects on the habitats.

Some solar power plants may require **water** for cleaning solar collectors and concentrators or for cooling turbine generators. Using large volumes of ground water or surface water may affect the ecosystems that depend on these water resources.

Chapter 01

In addition, the beam of concentrated sunlight a solar power tower creates can kill birds and insects that fly into the beam.

Furthermore, some **toxic materials** and chemicals are used to make the photovoltaic (PV) cells that convert sunlight into electricity. Some solar thermal systems use hazardous fluids to transfer heat. Leaks of these could harm the environment. During the life of the PV system, substances are not emitted that might be harmful to the health or environment. However, a great amount of energy is needed in their production.

And of course, at the **end of their useful life**, the installation must be disposed of and the residues dealt with.

1.11.1 Environmental Effects of PV System Production

1.11.1.1 Hazardous materials

The production phase of each PV technology can be described in terms of a production cycle, which includes potential pollutants or hazardous waste associated with each production step.

Perhaps the most important common denominator associated with all PV technologies is the material used for cleaning the cells. The PV cell manufacturing process includes hazardous materials, most of which are used for the cleaning and purifying of the semiconductor surface. In all cases, high levels of cleanliness are required to maximize performance, and in some cases the solvents used are highly toxic. The common means of dealing with these solvents is to confine them and then recycle them.

1.11.1.2 Life cycle and global warming emissions

While there are no global warming emissions associated with generating electricity from solar energy, there are emissions associated with other stages of the solar life-cycle, including manufacturing, materials transportation, installation, maintenance, decommissioning and dismantlement.

Most estimates of life-cycle emissions for photovoltaic systems are between 0.07 and 0.18 pounds of carbon dioxide equivalent per kilowatt-hour.

1.11.1.3 Recycling

What happens when solar panels are no more of use?

Although solar panel recycling has not become a major problem yet, it will in the coming decades because solar panels need to be replaced. When solar panels break, it is possible that they leak chemicals which are sealed in a functional module. If solar panels are not disposed of properly, chemical leaking may be a widespread issue. [8]

Chapter01

1.11.2 Environmental Effects of PV System Deployment and Operation

1.11.2.1 Land use

Depending on their location, larger utility-scale solar facilities can raise concerns about land degradation and habitat loss. Total land area necessities differ depending on: technology, topography of the site, and the intensity of the solar irradiance.

Impacts on land from utility-scale solar systems can be minimized. by placing them at lower-quality locations like brownfields, abandoned mining land... Smaller scale solar PV arrays, which can be built on homes or commercial buildings, also have minimal land use impact.

1.11.2.2 Deployment

The deployment of PV systems has associated environmental and health costs similar to the deployment of other energy technologies. Steel, aluminum and concrete can be expected to be part of the structures upon which the PV arrays and associated components will be mounted.

1.11.2.3 Water use

Solar PV cells do not use water to produce electricity. However, some water is used to manufacture solar PV components.

Chapter01

I.12 REFERENCES

- [1] Wikipedia. Énergie solaire. Wikipédia. February 5, 2020. Available at http://fr.wikipedia.org/w/index.php?title=%C3%89nergie_solaire&oldid=167094266 (consulted the 14th of February 2020)
- [2] Roger A. Messenger, Jerry ventre. The sun. Photovoltaic systems engineering second edition. Boca Raton London New York Washington D.C: Taylor & Francis e-Library, 2005, 435p
- [3] ENCYCLOPÆDIA BRITANNICA.Latitude and longitude. The Editors of Encyclopaedia Britannica .February 11, 2020. Available at <https://www.britannica.com/biography/Harold-Jeffreys> (Consulted the 15th of February 2020)
- [4] Kwok S. (2017) A Spherical Earth. In: Our Place in the Universe. Springer, Cham
- [5] Campbell scientific. Ce que vous devez savoir sur les pyranomètres. Alan Hinckley. June 14, 2017. Available at <https://www.campbellsci.fr/blog/pyranometers-need-to-know> (Consulted the 17th of February 2020)
- [6] Naim houcine, << etude de gestion d'une mini centrale solaire et mise au point d'un dispositif de mesure contrôle et régulation de l'énergie électrique>>. PhD thesis, university USTO department of physics faculty of energy physics 2015/2016.
- [7] B. Mamri, M. Zaidi “contribution de système photovoltaïque avec pompage”, Mémoire d'ingénieur en électronique, Université de Constantine, 2006.
- [8] Kuby Renewable Energy Ltd. The Positive and Negative Environmental Impacts of Sol Panels. Available at <https://kubyenergy.ca/blog/the-positive-and-negative-environmental-impacts-of-solar-panels> (consulted the 23rd of February 2020)
- [9] International Journal of Scientific & Engineering Research Volume 4, Issue3, March-2013 ISSN 2229-5518
- [10] Tamer KHATIB, Wilfried ELMENREIKH. Modeling of photovoltaic systems using Matlab. Hoboken, New Jersey. John Wiley & Sons, Inc. 2016
- [11] Bernard Fontaine, La production photovoltaïque d'électricité : quelles perspectives pour le Pays Provence Verte, 2009.
- [12] Mohamed Sedik, Etude des paramètres impactant sur le rendement d'un capteur solaire, Université Badji Mokhtar Annaba, thèse de master, 2018.
- [13] Mohamed Ould Salem, Analyse, modélisation et simulation des pertes dans un module photovoltaïque à base de silicium monocristallin, mémoire de magister, Université Abou Baker Belkaid Tlemcen, 2010.
- [14] Thomas Mambrini, Caractérisation de panneaux solaires photovoltaïques en conditions réelles d'implantation et en fonction des différentes technologies, Université Paris Sud, thèse de doctorat, 2014.
- [15] Jean François, Panneau solaire : rendement et cellules photovoltaïques, [En ligne]. Available : <https://conseil.manomano.fr/panneau-solaire-rendement-et-cellules-photovoltaïques-2883>.

Chapter01

[16] : MARTIN A. GREEN Photovoltaics Special Research Centre, University of New South Wales Sydney 2015

[17] : Amanda Ruth, Organic Semiconducting Oligomers for Use in Thin Film Transistors, Chemical Reviews, 2007

[18] : Soteris A. Kalogirou, McEvoy's Handbook of Photovoltaics, 3rd Edition, 2017.

[19] : AHM Smets, K Jäger, O Isabella, RA Swaaij, M Zeman, Solar Energy: The physics and engineering of photovoltaic conversion, technologies and systems, UIT Cambridge 2015

[20] : M. A. Green, K. Emery, Y. Hishikawa and W. Warta, Solar Cell Efficiency Tables (Version 33). Prog. Photovolt: Res. Appl., 2009.

[21] : Marzella Gorig, Christian Breyer, Energy Learning Curves Of PV Systems, Environmental Progress & Sustainable Energy, 2016.

[22] : Malik Abdul Rehman, Sanjib Baran Roy, Thickness-dependent efficiency of directly grown graphene based solar cells, Carbon, 2019.

[23] : Abdoulwahab Adaine, Optimisation numérique de cellules solaires à très haut rendement à base d'InGaN, Science, 2017.

2 CHAPTER02: ANALYSIS AND EVALUATION OF THE IMPACT OF ENVIRONMENTAL CONDITIONS ON PV CELLS PERFORMANCE BASED ON THE I-V CURVE



Chapter02

2.1 INTRODUCTION

Photovoltaic conversion is an energy application highly dependent on Environmental variables. The characteristic variables of solar cells, i.e. the short-time current circuit (I_{cc}), the open circuit voltage (V_{co}), the form factor (FF) and PV conversion (η) are all influenced by weather changes. The dependence of these parameters on environmental parameters namely temperature, solar irradiance, shading...and so on is studied in this chapter. we will look for a better understanding of solar cells, using electrical and environmental parameters.

2.2 WHY SHOULD WE STUDY OR PREDICT THE PERFORMANCES OF THE PV CELL? [1]

Photovoltaic systems are composed of multiple solar cells that are connected in series and in parallel to produce electricity. These solar cells have inherent low efficiency conversion rate due to the manufacturing process and materials used in PV cell production, as well as variations in PV cells operating conditions which involve solar insolation received, temperature effects, shading conditions, dust etc. All these points have caused, low-energy production by PV generators and put up the poor performance and high-priced maintenance of PV infrastructure, leading to loss of investment capital. The most important investment decision when it comes to implementing photovoltaic (PV) array(s) either for commercial or private application, is the levelized cost of energy (LCOE) calculation. Whereas LCOE, used as an assessment tool, to calculate the cost effectiveness of energy generation in relation to the return over investment in a prescribed time, can be calculated with a simple mathematical equation; it remains unattainable without a proper systems dynamic modelling and performance prediction of PV modules in the array(s). PV cells are unpredictable and have very low conversion efficiency of about 15-25% which makes it often necessary that maximum power point tracking (MPPT) system is integrated to PV modules to get optimum energy yield. This draw back, makes it quite crucial that output power and performance prediction of Photovoltaic systems at module level are established as a precursor to PV solar system design and implementation. This is key to sustaining efficient energy production by the PV generators, as it helps to detect if the DC power output of the PV modules is at optimum. In reality; it is quite challenging to correctly envision the performance of PV array power output due to variable factors like solar insolation, sun incident angle, temperature, PV array configuration, dust and non-uniform illumination amongst many factors. All these factors create nonlinear output characteristics in PV modules which results into instability in energy yield, faults, losses and costly maintenance of the PV infrastructure. Based on this clear indicators and reasons, the modelling and performance prediction of PV array becomes very essential in the design, implementation and operation of PV generators. Research shows that most PV installations exhibit on an average 20% to 25% power loss in energy production, due to the factors mentioned.

Chapter02

Modelling and prediction provide an expert review of the energy production profile at different times under varying conditions. The ability to predict PV arrays at module level will increase its performance, and supply the visibility required in discovering if the PV generator meets the electrical power supply demand and design specification.

2.3 EXTERNAL SOLAR CELL PARAMETERS [2]

The principal parameters that are used to characterize the performance of solar cells are the peak power P_{max} , the short-circuit current density J_{sc} , the open-circuit voltage V_{oc} , and the fill factor FF . The conversion efficiency η can be disposed from these parameters.

2.3.1 Short-circuit current density

The short-circuit current I_{sc} is the current that circulates through the external circuit when the electrodes of the PV cell are short circuited. The short-circuit current of a PV cell depends on the luminous flux density incident on the solar cell, which is determined by the spectrum of the incident light. For a standard solar cell measurement, the spectrum is standardized to the AM1.5 spectrum. The I_{sc} depends on the area of the solar cell. In order to detach the dependence of the PV cell area on I_{sc} , often the short-circuit current density is used to describe the maximum current delivered by a solar cell. The maximum current that the solar cell can convey firmly depends on the optical properties of the PV cell, such as absorption in the absorber layer and reflection.

2.3.2 Open-circuit voltage

It is the voltage at which no current circulates in external circuit. It is the maximum voltage that a PV cell would deliver. V_{oc} corresponds to the forward bias voltage, at which the dark current compensates the photocurrent. V_{oc} depends on the photo-generated current density. V_{oc} relay on the saturation current of the solar cell, the photo-generated current and is a measure of the quantity of recombination in the device.

$$V_{co} = \frac{kT}{q} \ln \left(\frac{I_{ph}}{I_s} + 1 \right)$$

Where:

I_s is the saturation current;

I_{ph} Illumination-dependent photo-current;

q the charge of the electron;

k the Boltzmann constant;

T the temperature;

n the ideality factor of the diode which takes into account recombination (in the case of ideal, it is equal to 1).

Two regimes can be observed depending on the degree of illumination:

-Low luminous flux regime: in this case, $I_{ph} \ll I_s$ which makes it possible to write $\ln\left(\frac{I_{ph}}{I_s}+1\right) \approx \frac{I_{ph}}{I_s}$

so $V_{co} = \frac{kT}{q} \frac{I_{ph}}{I_s}$ it is the area of linear behavior of the cell.

Chapter02

-Regime of the luminous fluxes sufficiently intense so that $I_{ph} \gg I_s$, $\frac{I_{ph}}{I_s} > 1$ so $V_{co} = \frac{KT}{q} \ln \left(\frac{I_{ph}}{I_s} \right)$ it's the domain of logarithmic behavior.

2.3.3 Fill factor

The fill factor is an important parameter for defining the quality of a cell. It is the proportion between the maximum power ($P_{max} = I_{mp} \cdot V_{mp}$) generated by a solar cell and the product of V_{oc} with J_{sc} .

$$FF = \frac{I_{mp} V_{mp}}{J_{sc} V_{oc}}$$

It is a measure of the quality of the connection as well as of the series or parallel resistors operating in the cell. The closer the fill factor is to 1, the better the cell.

2.3.4 Conversion efficiency

The conversion efficiency is calculated as the ratio between the maximal generated power and the incident power. The irradiance value P_{in} of 1000 W/m² for the AM1.5 spectrum has become a standard for measuring the conversion efficiency of solar cells.

$$\eta = \frac{P_{max}}{P_{in}} = \frac{I_{mp} V_{mp}}{P_{in}} = \frac{J_{sc} V_{oc} FF}{P_{in}}$$

2.4 CHARACTERISTICS

2.4.1 the characteristic equation of the photovoltaic cell

The current-voltage characteristic of a solar cell [3] is calculated as the following mathematical form:

$$I = I_{ph} - I_0 \cdot \left[\exp \left(\frac{V + IR_s}{\hat{a} \cdot V_t} \right) - 1 \right] - \frac{V + IR_s}{R_p}$$

R_s: Serial resistance (Ω).

R_p: Shunt resistance (Ω).

I: The current supplied by the cell (Ampere).

I_{ph}: Illumination-dependent photo-current (Ampere).

I₀: The saturation current of the diode (Ampere).

\hat{a} : diode ideality factor.

$V_t = kT/q$ thermal potential.

2.4.2 Characteristic I(V)

A photovoltaic cell has a non-linear I(V) characteristic tested in illumination conditions of 1000W/m^2 , has an AM1.5 spectrum and cell temperature of 25°C and which has the appearance expressed in the following figure:

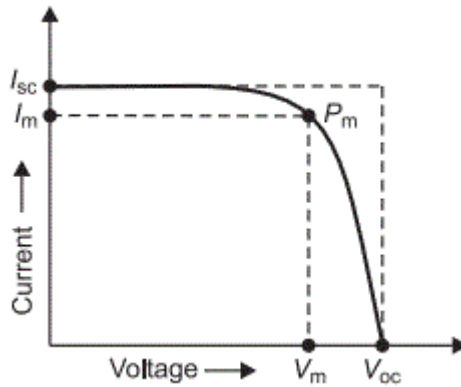

Figure 23: I(V) characteristics of a PV cell

P_m : Maximum power

V_m : Maximum voltage

I_m : Maximum current

I_{sc} : short-circuit current

V_{oc} : open circuit voltage

The variation of the current "A" (or current density "A/cm²") in response to the voltage "V", in the dark and in particular under illumination, makes it possible to evaluate the performance of the solar cell.

2.4.3 Characteristic P(V)

The power provided by the cell is expressed as P(V). For each point of the curve $I=f(V)$, a power P is calculated, and therefore a curve $P=f(V)$ is plotted. It looks like this:

Chapter02

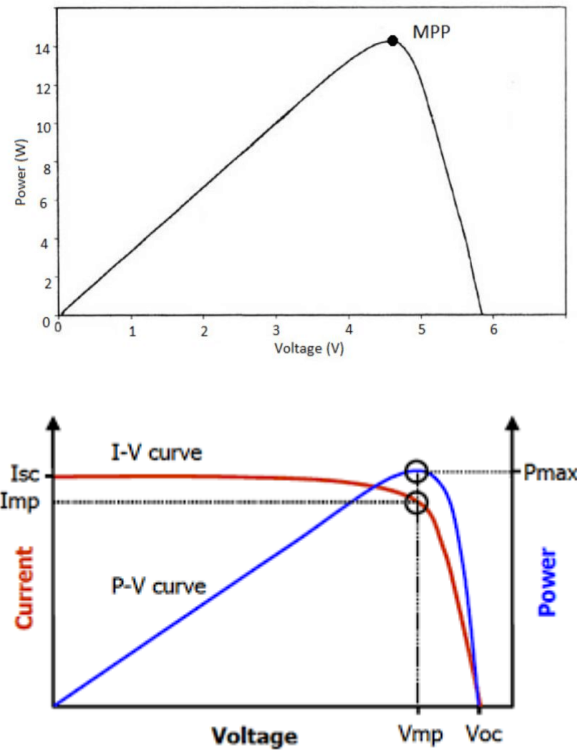

Figure 24: $P(V)$ characteristics of a solar cell

Mpp is the maximum power point.

2.5 ELECTRICAL MODEL

The equivalent circuit of an electrical system is frequently used to describe its electrical behavior using elementary electrical components (source, resistor, diode, coil, capacitor, etc.). In the literature, there are several models of photovoltaic cells whose objective is to determine the current-voltage characteristic $I(V)$ for the analysis and evaluation of the performance of photovoltaic modules. Two models are mainly used: the one diode and the two-diode model.

2.5.1 One diode model

2.5.1.1 Ideal model

Experience shows that in the dark, a solar cell follows the behavior of a conventional diode, it starts to conduct when the voltage applied exceeds the threshold voltage V_s . In the case of an ideal cell in the dark, the I-V characteristic can be represented by the following relation:

$$I_d = I_0 \left[\exp\left(\frac{V_d}{V_t}\right) - 1 \right]$$

I_d : Diode current (Ampere).

I_0 : Reverse saturation diode current (Ampere).

Vd: The voltage at the diode terminal (Volt).

Vt: $=KT/q$ thermal potential

A photovoltaic cell can be described in a simple way as an ideal current source that produces a current I_{ph} proportional to the incident light power, in parallel with a diode that corresponds to the transition area p-n of the PV cell. The diode model is the most classical and the frequently used model, it uses a current generator to model the incident luminous flux, and a diode for the cell polarization phenomenon.

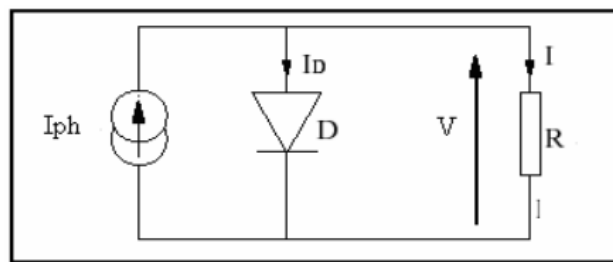

Figure 25: ideal modal of a solar cell

2.5.1.2 Real modal

The previous photovoltaic model did not account for all the phenomena present during the conversion of light energy. Indeed, in the real case, we observe a loss of output voltage and leakage currents. This voltage loss is therefore modelled by a serie resistor R_s and the leakage currents by a parallel resistor R_p .

So, to take into account the electrical model, a serie resistance R_s and shunt R_p are associated with the circuit. The Serie resistance is due to the contribution of the base resistors, the junction front and back contact resistors. The shunt resistance identifies the leakage current of the junction along the periphery of the cell; it is reduced as a result of the penetration of metallic impurities into the junction (especially if it is deep), during the deposition of the grid.

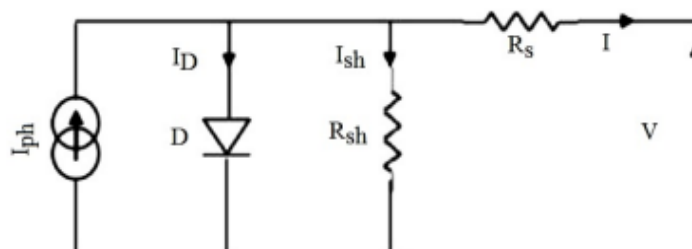

Figure 26: real modal of a solar cell

Chapter02

- ❖ The current generator (I_{ph}): it delivers the I_{ph} current corresponding to the photogenerated current.
- ❖ The diode (D): models the P-N junction.
- ❖ The serie resistor R_s : models the resistive losses within the cell (the metallization). It is related to the impedance of the electrodes and the material; as a result, the voltage V across the cell is different from the voltage across the pn junction. This term should ideally be as low as possible to limit its influence on the cell current.
- ❖ The parallel resistance R_p (shunt resistance R_{sh}): corresponds to a leakage resistance between the two zones n and p of the junction; as a result, a part of the current I_{ph} will be derived by this resistance and cannot be delivered to the load. This resistance should be as high as possible.

2.5.2 Two diode model

In reality, the recombination phenomenon represents significant losses that cannot be properly modeled using the single-diode model. Consideration of these losses leads to the introduction of an additional diode.

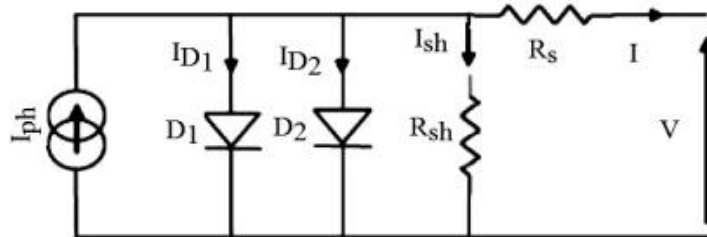

Figure 27: Two diode model

These diodes symbolize the recombination of minority carriers, on the one hand on the surface of the material and at the same time in the volume of the material.

- * The diode (D1): models the diffusion of carriers in the base and transmitter. Its influence will be greater the longer the material has a good diffusion length.
- * The diode (D2): models generation/recombination in the space charge zone.

2.6 ELECTRICAL PARAMETERS INFLUENCING THE PERFORMANCE OF A PHOTO-VOLTAIC CELL

Generally, when a study about the performance of a cell is conducted, we study its influence on the characteristic $I(V)$ of the cell:

2.6.1 Influence of the Serie resistance

The series resistance is an internal resistance of the cell, it depends mainly on the resistance of the semiconductor used, the contact resistance of the collector gates and the resistivity of these gates.

The series resistance influences the I(V) characteristic of the solar cell, it can change the shape of the curve. It acts on the slope of the characteristic in the area where the photodiode behaves as a voltage generator.

The open circuit voltage (V_{co}) and the short circuit current (I_{cc}) do not change, but the characteristic is distorted very quickly by R_s . This influence is reflected by a decrease in the slope of the I-V characteristic in the area where the cell functions as a voltage source when R_s increases. The increase in series resistance has a considerable reducing effect on the operating point and the form factor (FF) of the cell. This results in lower cell efficiency. when it is high, it decreases the value of the short-circuit current.

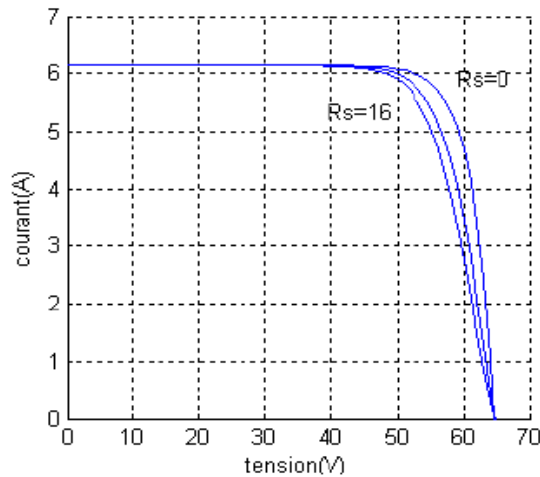

Figure 28: Characteristic I (V) of a module for different series resistance values.

The influences mentioned above can be clearly seen in **figure28** which is a result of an experience done on monocrystalline cells with the conditions: $T=25^{\circ}\text{c}$, $G=1\text{W}/\text{m}^2$, $R_s= 0,8,16\text{mOhm}$.

2.6.2 Influence of the shunt resistance

The shunt/parallel resistance is a resistor that takes into account unavoidable current leakage (leakage current between cells, leakage current between the cell and the border of the module etc.).

In general, the shunt resistance is very high, its effect is felt especially in the current generation part.

the open-circuit voltage (V_{co}) and the short-circuit current (I_{cc}) does not change, but the characteristic is deformed very quickly, this influence reflect in an increase in the slope of the I-V characteristic of the cell in the region corresponding to operation as a power source (low voltage).

Chapter02

Shunt resistance can be caused by defects within the material, such as: dislocations...in the depletion zone or along the solar cell. In fact, too low shunt resistance will have an impact on the open circuit voltage of the solar cell; because of this, a solar cell with too low shunt resistance will no longer give voltage under low illumination.

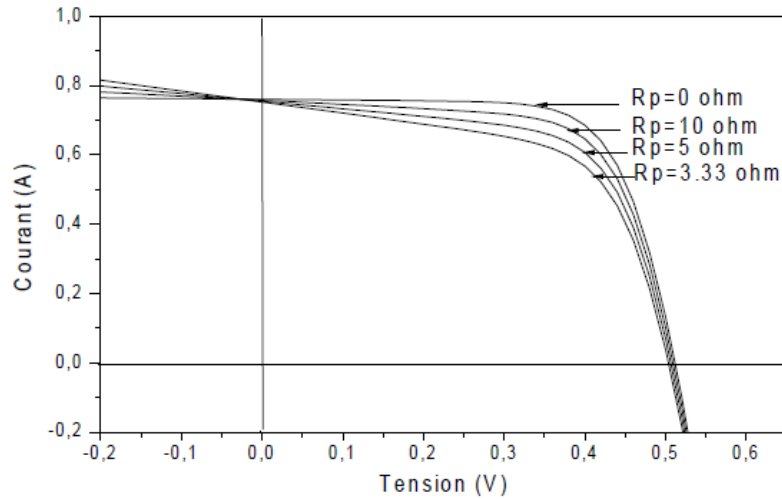

Figure 29: effect of the shunt resistance on the I-V characteristic of an illuminated solar cell

In **figure29** all what is mentioned before about the influence of the shunt resistance on solar cells is well represented.

2.6.3 Influence of the saturation current (I_s)

The rise in the saturation current causes a reduction in the open circuit voltage, whereas the short-circuit current remains constant. A decrease in the saturation current I_s leads to an increase in V_{oc} . Note that a decrease by a factor of 10 of I_s , only leads to an increase of 50mV of V_{oc} .

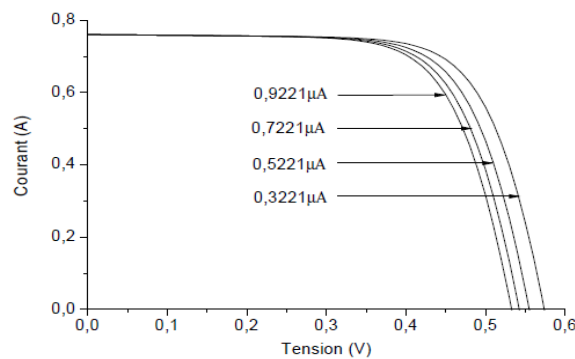

Figure 30: influence of the saturation current on the I-V characteristic of an illuminated solar cell. Characteristics formed by simulation using the following selective values: ($R_s=0.0364 \Omega$, $R_{sh}=53.7634 \Omega$, $I_s=0.3221 \times 10^{-6}$: 2.0×10^{-7} : 0.9221×10^{-6} A, $n=1.4837$, $t=33^\circ\text{C}$).

2.6.4 Influence of the ideality factor (n)

The decrease in the ideality factor (n) causes a reduction of the open circuit voltage (V_{co}) while the short current circuit (I_{cc}) remains constant.

Its increase inversely affects the maximum power point of the cell.

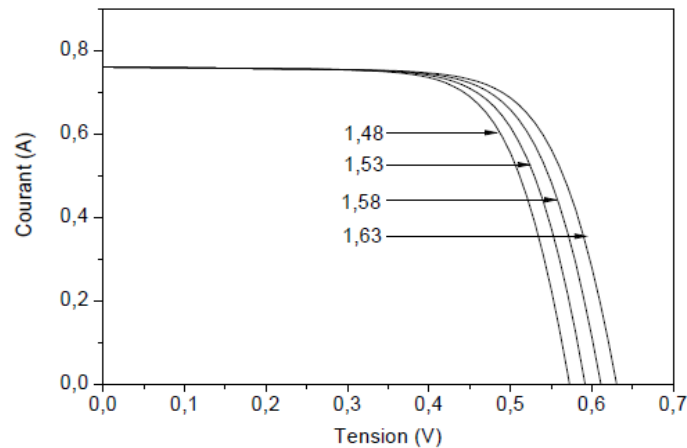

Figure 31: influence of the ideality factor on the I-V characteristic of an illuminated solar cell. Characteristics formed by simulation using the following selective values: ($R_s=0.0364 \Omega$, $R_{sh}=53.7634 \Omega$, $I_s=0.3223 \times 10^{-6}$, $n=1.48:5.0 \times 10^{-2}:1.63$, $t=33^\circ\text{C}$, $I_{ph}=0.7608 \text{ A}$)

2.7 ENVIRONMENTAL PARAMETERS INFLUENCING THE SOLAR CELL

2.7.1 Influence of temperature

Temperature is a very important parameter in the behavior of PV cells since they are exposed to solar radiation. The current increases with temperature; on the contrary, the open circuit voltage decreases. This leads to a decrease in the maximum power available. This can be explained by the decrease in the gap, which causes the concentration of the carriers of load, as the transition between levels becomes more likely.

The increase in temperature leads to a decrease in voltage (V_m) and a slight increase in current (I_m) and subsequently a relative decrease in maximum power (P_m).

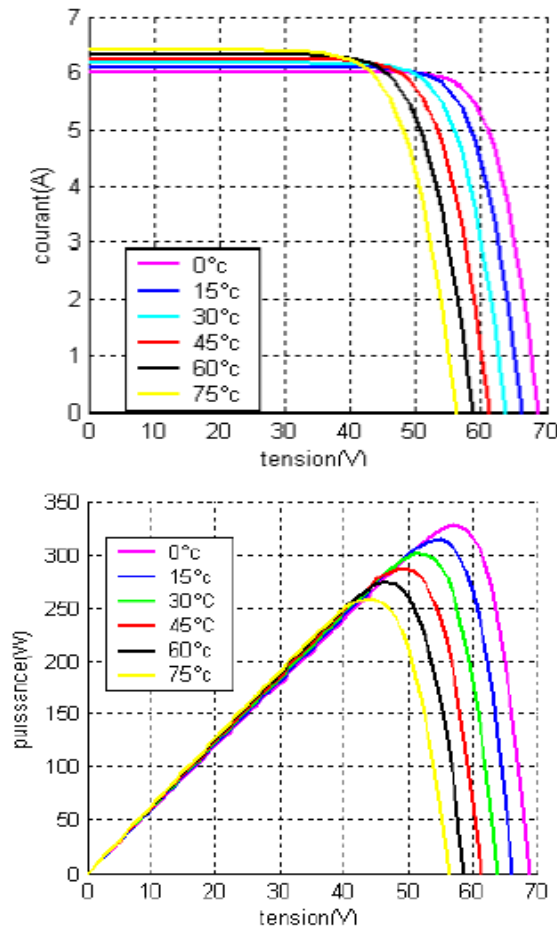

Figure 32: influence of temperature on $I(V)$ and $P(V)$ characteristics

Figure 32 describes the behavior of monocrystalline cells under a fixed illumination of $1\text{W}/\text{m}^2$ and at temperatures between 0°C and 75°C .

2.7.2 Influence of illuminance:

The short-circuit current I_{cc} is directly proportionate to the incident luminous intensity; the variation of I_{cc} with illuminance is given as follows:

$$I_{cc} \approx I_{ph} = \alpha(T) \times E \times S$$

E : is the illuminance in W/m^2 .

S : is the cell area in m^2 .

$\alpha(T)$: coefficient weakly dependent on temperature, it is expressed in A/W .

On the other hand, the increase in illuminance causes a slight increase in open circuit voltage V_{co} .

At a constant temperature, the current undergoes a large variation, but the voltage varies slightly, because the short-circuit current is a linear function of the illuminance whereas the open circuit voltage is a logarithmic function.

This can be clearly seen in **figure33** where we represent the results concerning the I(V) and P(V) characteristics of a monocrystalline cell at a constant temperature of 25°C obtained for various illuminance values.

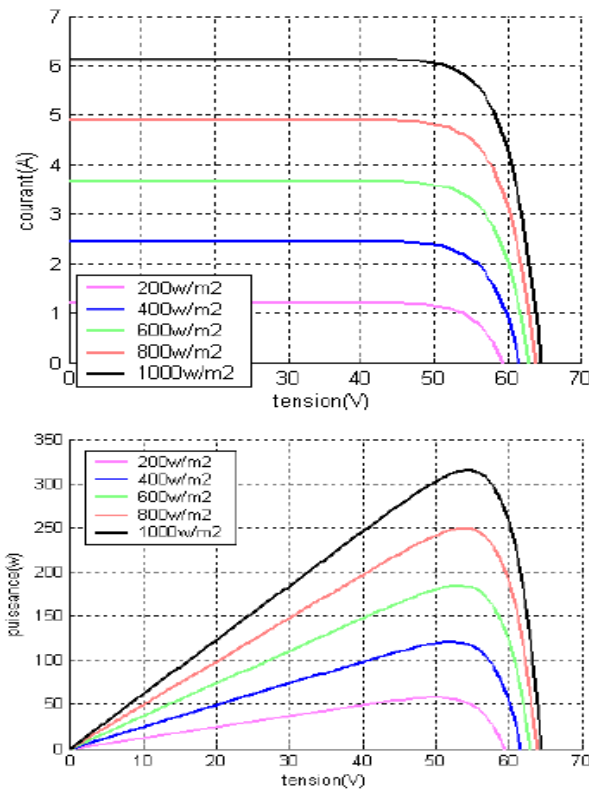

Figure 33: Characteristic I (V) and P(V) of a module for different illuminance values.

2.7.3 Shading influence

Many factors can cause shading, such as trees, clouds, snow, sand, dust, utility poles and buildings. There are two types of shading, one at the cell level and the other at the module level. We find them in the literature under the denomination: partial shading affecting only one cell and homogeneous shading affecting the module.

- * Homogenous: In this case the distribution of the incident lighting is homogeneous over the entire cell surface.
- * Partial: In this case the distribution of the incident light is not homogeneous over the entire surface of the photovoltaic cell or module.

under different shading conditions there is a very strong decrease in the current and power carried out by the panel.

If, for a given solar irradiance and ambient temperature, the current flowing through a cell is greater than its short-circuit current, then the cell will operate in reverse-bias conditions with a negative voltage. In this case, the excess power will disappear as heat in the shaded cell or cell encapsulation may be irreparably damaged. This effect is called 'hot spot'. In the forward range (normal operating mode), the open circuit voltage of the cell is about 0.6 V for crystalline cells while in the inverted (reverse bias), voltages can reach more than - 20 V in the case of silicon.

so as not to risk compromising the profitability, Yield losses due to shading conditions must be minimized at the planning stage. One of the solutions is the use of bypass diodes, which are diodes that are placed in anti-parallel with each cell.

The I(V) and P(V) characteristics of a PV module are shown in **figure34**, of which only one solar cell (CIGS) had been shaded, for different shading rates. 0% (the whole cell is illuminated), 20% (5cm of the cell is hidden), 40% (10cm of the cell is hidden), 60% (15cm of the cell is hidden), 80% (20cm of the cell is hidden) up to 100% (where the whole 25cm cell is shaded). [3]

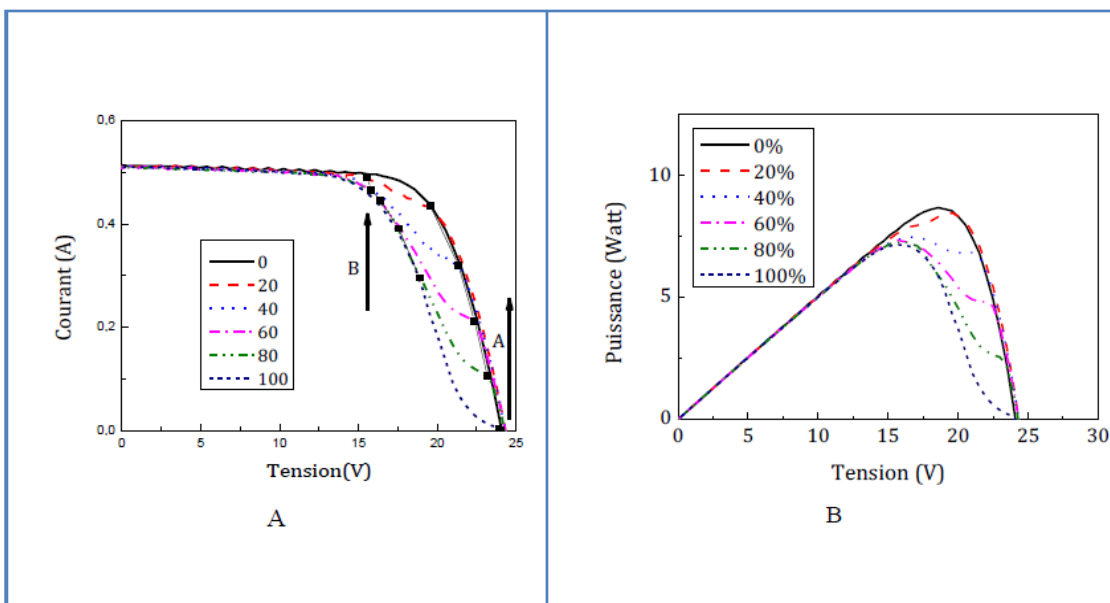

Figure 34: Module characteristics as a function of shading rate, where: A-current-voltage, B-power-voltage

It can be seen that the general shape of the characteristics I(V) and P(V) of the module photovoltaic system has undergone significant deformations, with the increase in the rate of shading, which implies their non-uniformity. Indeed, the reduction of the short-circuit current of the shaded cell is obvious, since the current generated has decreased as a function of increasing the rate of shading. The decrease in module current is appreciable between two points, namely:

Chapter02

-Point A where the shading effects on the module begin to appear;

-Point B where the bypass diode is activated.

The influence of the inverse characteristic of the shaded cell is seen in the area delimited by the point where the short-circuit current of the shaded cell is exceeded (point A) and, the point where the bypass diode is activated (point B). A cell with a high shunt conductance, its effect on the distortion of the I(V) characteristic will be less.

However, this happens when the current flowing through the cells of the module is the same (cells in series) and the illumination level is different (a shaded cell), with the voltage at the terminals of the shaded cell is different from that of the others which are illuminated.

Another effect of shading is the displacement of the point of maximum power to lower voltage values. In fact, shading of 2.77% of the module, which corresponds to 100% shading of the cell, results in a power reduction of around 17.43% which is dissipated as heat.

2.8 DSSC

Dye-sensitized solar cell _DSSC_, invented by O'Regan and Gratzel, have reached energy yields of 11% under standard test conditions _AM1.5 G=100 mW/cm² at 298 K making it a highly credible alternative to *p-n* junction photovoltaic devices.

The DSSC based porous TiO₂ thin film has a reasonable price and high efficiency. They are therefore, favorable in taking up the huge energy opportunities that exist. However, their performance is mannered by environmental conditions such as ambient temperature and incident light intensity. A key factor to make them appealing is the better understanding of their long-term stability and performance under weather conditions.

2.9 EQUIVALENT CIRCUIT OF A DSSC

It allows to analyze the electrical process and properties of the cell. The simple equivalent circuit is made of the current source, diode, capacitances, and the resistances. The current source generates the I_{PH} (photoelectric current) in proportion to the irradiation of sunlight. The C_{pt} and R_{pt} are the impedance through carrier transport on the surface of the counter electrode. The C_{ELEC} and R_{ELEC} are the impedance with regard to carrier transport through the ions in the electrolyte, and those are worked as the diode with regard to electron transfer of TiO₂/dye/electrolyte facing surface. R_{TCO} is the resistance through the surface resistance. R_{SH} is shunt resistance through the back-electron transfer.

The capacitance elements can be ignored because the values of the capacitances are fairly large. That is why the circuit will be simplified such as current source, diode, one of parallel resistance, and three of series resistances. [4]

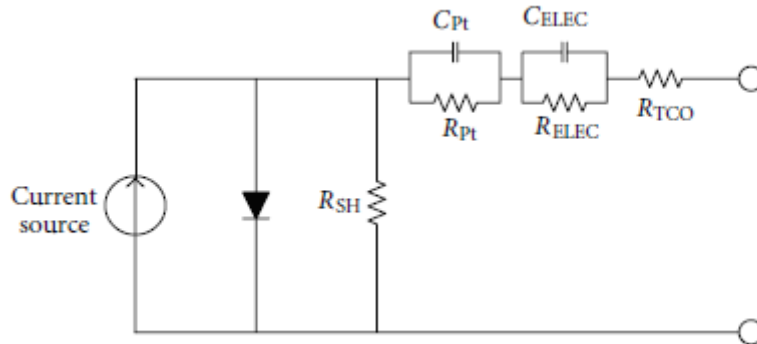

Figure 35: equivalent circuit of a DSSC

The current of the diode is given as:

$$I_D = I_O \left\{ \exp \left(q \frac{V + IR_S}{nkT} \right) - 1 \right\}$$

The current of the shunt resistance:

$$I_{SH} = \frac{V + IR_S}{R_{SH}}$$

And R_{TCO} , R_{ELEC} , and R_{Pt} are incorporated as RS

The output current is:

$$I_O = I_{PH} - I_D - I_{SH} = I_{PH} - I_D \left\{ \exp \left(q \frac{V + IR_S}{nkT} \right) - 1 \right\} - \frac{V + IR_S}{R_{SH}}$$

To understand more the relation between the functioning of the DSSC and its circuit another representation is done in **figure36**.

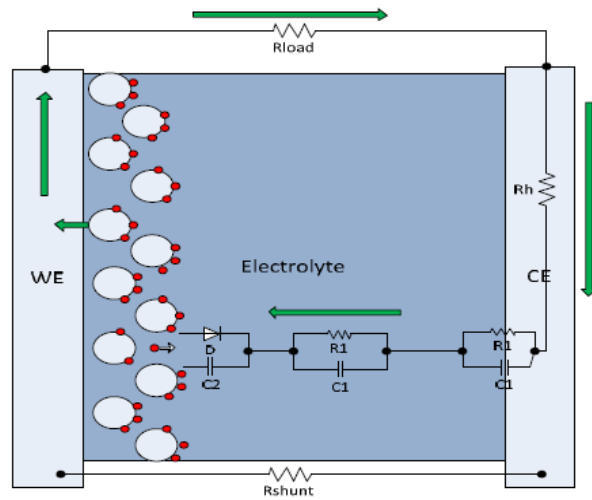

Figure 36: DSSC equivalent circuit model.

Figure36 shows the flow of electrons in a DSSC once exposed to light with an equivalent circuit model overlaid. The electrons flow:

- From dye to titanium dioxide following light exposure: represented by D in parallel with C2
- From the titanium to the working electrode.
- From the working electrode, WE, through the load resistance to the counter electrode, CE: represented by Rh.
- From the counter electrode, CE, to the electrolyte: represented by R3 in parallel with C3.

R_{shunt} represents the open circuit resistance of the system, and is substantially higher than the other resistances. For clarity, the DSSC equivalent circuit is shown separately in **Figure37** [5].

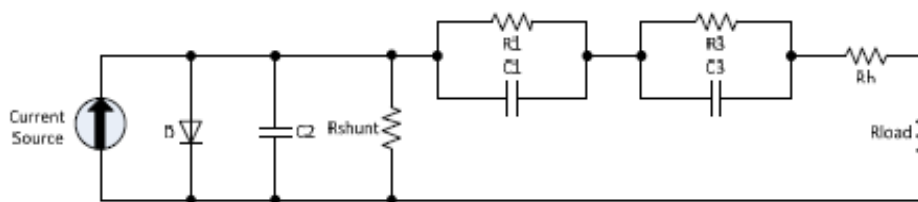

Figure 37: equivalent circuit of a DSSC

capacitors act like open circuits and it is found that resistive components, R1 and R3 are most significant. R1 represents the resistance of the path given through the electrolyte and is proportional to the electrolyte layer thickness, while being inversely proportional to the active cell area. Meanwhile, R3, representing the resistance between the electrolyte and the counter electrode (CE), is inversely proportional to the electrolyte-electrode interface area. Methods to reduce internal resistance have had some effect. [6]

2.10 PARAMETERS INFLUENCING THE PERFORMANCE OF A DSSC

The performance of the DSSC depending on different parameters is going to be represented and explained according to 3 published papers where different experiences on different types of DSSC were made.

2.10.1 Influence of electrical parameters

2.10.1.1.1 Influence of the Serie resistance

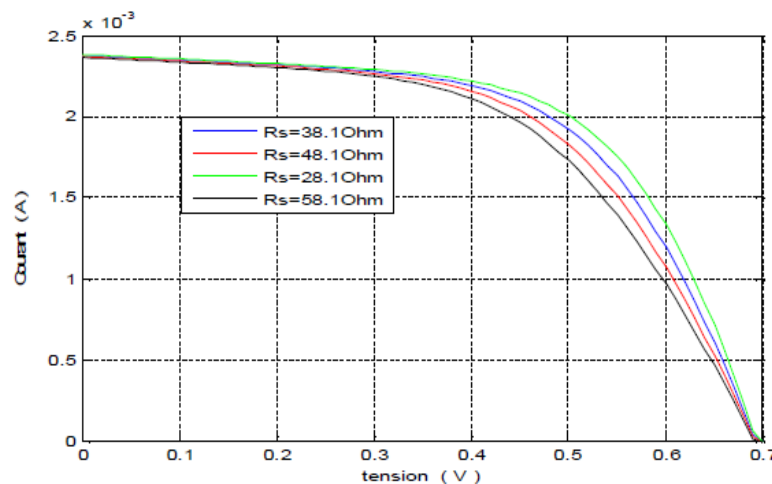

Figure 38: influence of Serie resistance on the DSSC

The figure above is the result of a simulation done on the equivalent circuit of the DSSC with the software Scilab. The result of the simulation is represented as the influence of the Serie resistance on the I(V) curve with different R_s values.

As seen before the R_s reacts on the slope where the cell behaves as a tension generator; and from the graph it is clear that as the value of R_s is bigger, the value of I_{cc} decreases. Leading to a decrease in the yield of the cell.

2.10.1.2 Influence of the shunt resistance

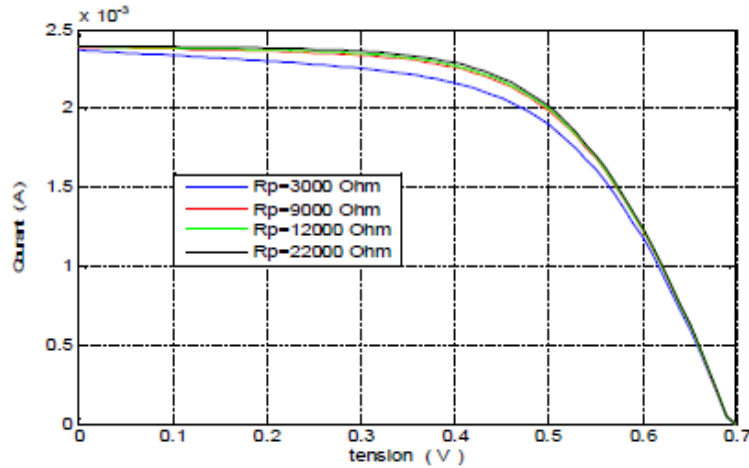

Figure 39: influence of shunt resistance on the DSSC

This graph is extracted from the same simulation as in the previous title.

The impact of the shunt resistance on the curve is translated by a light decrease of v_{co} ; as well as an increase of the curve in the zone corresponding to a functioning as a source of current.

2.10.2 Influence of environmental parameters

The environmental parameters such as temperature, irradiance and shadowing can have an effect on the characteristics of the DSSC, these effects are considered in the next section.

To establish the effect of the environmental parameters on the DSSC, we chose to rely on an experience done on a $1 \times 1 \text{ cm}^2$ size DSSC unit cell. In this experience the photovoltaic parameters of the cell were evaluated by a source meter unit under the standard test conditions (temperature= 25° , irradiance= 1000 W/m^2) using a solar simulator.

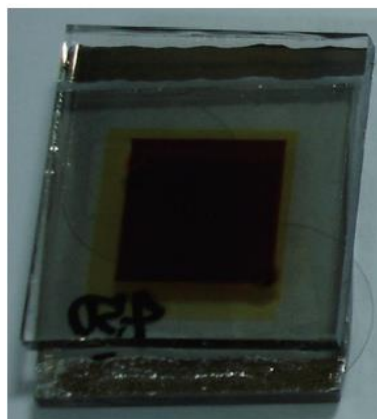

Figure 40: A $1 \times 1 \text{ cm}^2$ size DSSC unit cell.

2.10.2.1 Influence of temperature

To elaborate the dependence, we give several values of temperature while keeping the irradiation constant (1000 W/m²).

From **figure41**, we can see that the current is almost constant (it can increase or decrease in other cases when using a different cell or when simulating) but the voltage changes with temperature; it decreases by approximately 2.84 mV when temperature increases by 1°C. and so the MPPT also changes (by the alternating the voltage).

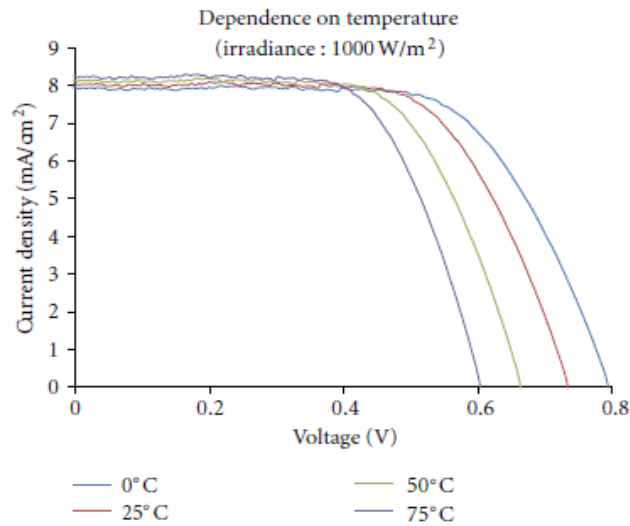

Figure 41: influence of temperature on DSSC

2.10.2.2 Influence of irradiation

Now, the temperature is constant at 25° and the irradiation changes.

From the figure below (**figure42**), the voltage is constant. The current changes linearly with the change of the irradiation. The maximum power point also changes by the change of the irradiation.

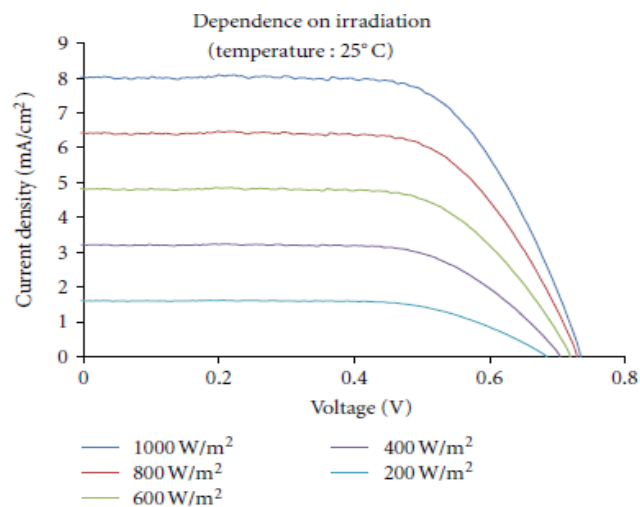

Figure 42: influence of radiation on DSSC

2.10.2.3 The shadowing effect

When a DSSC is under shadow it generates power losses in the form of heat because of the reverse current flow, but it is less effected by the shadow comparing to silicon cells.

The table below (**Table1**) shows the effect of shadow on the DSSC parameters. By increasing the shadow rate, the current greatly reduces, the voltage is little reduced so the power also reduces.

Shading rate	Parameter				
	V_{oc} (V)	I_{sc} (mA)	FF	η (%)	P_{max} (mW)
0%	0.734	8.186	0.643	3.863	3.863
25%	0.722	5.932	0.664	2.843	2.843
50%	0.716	4.026	0.707	2.039	2.093
75%	0.702	2.631	0.738	1.363	1.363

Table 1: Effect of shadow on the DSSC parameters.

2.11 CONCLUSION

When it comes to implementing photovoltaic array, the most important investment decisions is the cost of energy. This calculation remains steady without a proper system modeling and performance prediction. PV cells are unpredictable because they rely on environmental parameters, which are variable factors, in their functioning, and they have very low conversion efficiency. This draw back, show us that it is crucially important to conduct a study on the performance of solar cells taking into account environmental parameters. This is key to sustaining efficient energy production by the PV generators, as it helps to detect if the DC power output of the PV modules is at optimum [1].

Based on all of that, in this chapter, we have conducted a study on the performance of cells. In reality, to do so we need to actually produce a cell and study it's performance according environmental parameters around it; since we couldn't do that, we have decided to rely on studies that have already been done and published.

this chapter establishes a reliable modal to study correctly the influence of external and internal parameters. we presented an electrical modal, as well as characteristics which are Short-circuit current density, Open-circuit voltage, Fill factor, Conversion efficiency, I(V) and P(V) curves. The characterization of the photovoltaic cells model seems interesting; the influence of different climatic and other parameters on the characteristics I(V), P(V) was discussed.

We have concluded that Temperature is a very important parameter in the behavior of cells since they are exposed to solar radiation, the electrical performance of a solar cell is very sensitive to solar radiation, The performances of a photovoltaic cell are degraded when, R_s is big or R_{sh} is low, When a DSSC is under shadow it generates power loses in the form of heat but it is less effected by the shadow comparing to silicon cells.

In order to maintain a good optimized performance in practical applications, we suggest that solar cells should be installed in cold and sunny environments with using effective auxiliary facilities like solar concentrator and cooling system in order to control the light intensity and operating temperature.

2.12 REFERENCES

- [1] R. O. Kene, T. O. Olwal and S. P. Daniel Chowdhury, "Performance prediction of photovoltaic arrays," *2017 52nd International Universities Power Engineering Conference (UPEC)*, Heraklion, 2017, pp. 1-6, doi: 10.1109/UPEC.2017.8231991.
- [2] Klaus Jäger, Olindo Isabella, Arno H.M. Smets, René A.C.M.M. van Swaaij, Miro Zeman. *Solar Energy Fundamentals, Technology, and Systems*. 2014, Delft, the Netherlands. Delft University of Technology.
- [3] ATEK Mourad, << Effets du taux d'ombrage sur les performances des cellules solaires à base de CIGS>>. Magister thesis, Université Ferhat Abbas de SÉTIF, faculté des sciences, département de physique 19/09/2013.
- [4] Kyoung-Jun Lee, Jeong-Hoon Kim, Ho-Sung Kim, Dongsul Shin, Dong-Wook Yoo, and Hee-Je Kim, 2011, "A Study on a Solar Simulator for Dye Sensitized Solar Cells", *International Journal of Photoenergy*, Volume 2012, Article ID 834347, 11 pages.
- [5] David Newell, Maeve Duffy, 2014, "Effects of DSSC configuration on power conversion efficiency", *Power Electronics Research Centre NUI Galway*, vol. 5, pp.2.
- [6] L. Han, N. Koide, Y. Chiba, A. Islam, and T. Mitate, "Modeling of an equivalent circuit for dye-sensitized solar cells: improvement of efficiency of dye-sensitized solar cells by reducing internal resistance," *Comptes Rendus Chim.*, vol. 9, no. 5–6, pp. 645–651, May 2006.

3 CHAPTER03: PREDICTION MODEL FOR PV PERFORMANCE WITH CORRELATION ANALYSIS OF ENVIRONMENTAL VARIABLES



Chapter03

Chapter03

3.1 INTRODUCTION

Today, Photovoltaic energy is an important component of national and international energy policy. In the medium and long term, this component is expected to provide complementarity and effective diversification compared to traditional energy sources. the importance of establishing reliability in PV power systems is increasing as the use of PV power generation systems is expanding. [2]

The systems that integrate this source can be classified into two categories: installations connected to the grid and autonomous electricity supply systems, but because of the intermittent nature of this source, solar energy is an energy whose power is difficult to guarantee in advance. In the case of systems connected to the electrical grid, this phenomenon degrades the quality of the network. In fact, the photovoltaic power can be easily effected by environmental conditions like: Temperature, solar irradiance and shades, a sudden change in the weather can cause a drop in the available power, which can lead to the collapse of the electrical network in the case of systems connected to the network and sometimes it is necessary to use other conventional means of energy production in parallel with these sources in order to ensure the availability of the required power. The stability of solar power generation systems is generally evaluated in terms of the performance ratio. Usually, the performance ratio of PV power generation is in the range of 0.7–0.9[5]. Insolation and temperature are the primary factors affecting PV power generation. Increasing the temperature of a solar module causes a decrease in its power output. Generally, PV power output decreases by 0.4% for every 1 °C rise in temperature [6].

This type of prediction is essential to improve the quality and energy efficiency of these systems in order to increase their share of injection into large-scale power grids. For stand-alone RE (renewable energy) power supplies, prediction models will make it possible to quantify the available RE and to manage the transition between the different sources making up the energy mix in an optimal way.

Although various methods have been proposed for calculating PV power output, there are basically two ways of assessing the maximum amount of power produced by solar modules. The first approach calculates the instantaneous peak power based on the $I-V$ curve which was discussed in chapter02, under certain conditions, such as the standard test condition (STC).

The second approach, is the one we are using in this chapter, it uses regression analysis of long-term data on PV module power generation. These data can be used to build models of module operations at different meteorological and solar radiation values [2].

Chapter03

This chapter is organized as follows: we start with the description of the prediction method and the presentation of the system studied, we move to the technic used to record the measurements and we present the data. Finally, we compare and discuss the results of the simulation and of each model, followed by a conclusion.

3.2 HISTORY

The origin of the word regression comes from Sir Francis Galton. In 1885, working on, he tried to explain the size of the sons in relation to the size of the fathers. He found that when the father was taller than average, his son tended to be shorter than him and, conversely, when the father was shorter than average, his son tended to be taller than him. These results led him to consider his theory of regression toward mediocrity. However, the causality analysis between several variable is older and dates back to the middle of the eighteenth century. In 1757, R. Boscovich, born in Ragusa, present-day Dubrovnik, proposed a method minimizing the sum of absolute values between a causal model and observations. Then Legendre, in his famous 1805 article, "new methods for the determination of the orbits of comets", introduced the method of estimation by least squares of the coefficients of a causal model and gave the name to the method. At the same time, Gauss published in 1809 a work on the movement of the celestial bodies which contained a development of the method of least squares, which he claimed to have used since 1795 (Birke's & Dodge, 1993). [1]

3.3 DEFINITION

Linear regression is a linear model that allows estimates to be made in the future based on information from the past. In this linear regression model, we have several variables, one of which is an explanatory (Independent) variable and the others are explained (dependent) variables. It is used to analyze any phenomenon using so-called econometric statistical methods. Indeed, linear regression is a stochastic relationship between one or more variables. It is applied in several fields, such as physics, biology, chemistry, economics...etc.

Linear regression is one of the multivariate analysis methods that deal with quantitative data.

It is a method of investigation based on observational or experimental data, in which the main objective is to search for a linear relationship between a quantitative variable Y and one or more X variables that are also quantitative. This is the most widely used method for two major reasons:

- * It is an old method.

Chapter03

- * It is the basic tool for most of the more sophisticated models such as the logistic regression, the generalized linear model, the methods for processing series temporal, and especially econometric models, etc.

There are two types of linear regression, simple and multiple depending on the number of variables. The simple and multiple linear regression is a tool of analyze which calls upon three scientific domains, namely: Economic theory; statistics at analyze; and Mathematical modeling.

3.4 CORRELATION

The term correlation is used in everyday language to designate the relationship (relation / association) between 2 variables of any kind. In statistics, the correlation term is reserved to designate the link between 2 QUANTITATIVE variables (the more often continuous).

While the calculation of the correlation between X and Y informs us about the direction (globally positive, globally negative or globally zero) of the relationship between X and Y, as well as the "degree of accuracy" of this relationship, the linear regression that we introduce in this chapter will allow us to describe more precisely how the two variables are related.

3.4.1 Correlation coefficient

The correlation coefficient r , is used for the determination of the degree of association between two variables, x_i and y_i , it is expressed as follows:

$$r = \frac{\sum_{i=1}^n (x_i - \bar{x}_i)(y_i - \bar{y}_i)}{\sqrt{\sum_{i=1}^n (x_i - \bar{x}_i)^2 \sum_{i=1}^n (y_i - \bar{y}_i)^2}} \quad (1)$$

$$\bar{x}_i = \frac{1}{N} \sum_{i=1}^N x_i, \bar{y}_i = \frac{1}{N} \sum_{i=1}^N y_i \quad (2)$$

We apply (1) to (2) and we get r :

$$= \frac{n \sum_{i=1}^n x_i y_i - \sum_{i=1}^n x_i \sum_{i=1}^n y_i}{\sqrt{n \sum_{i=1}^n x_i^2 - (\sum_{i=1}^n x_i)^2} \sqrt{n \sum_{i=1}^n y_i^2 - (\sum_{i=1}^n y_i)^2}}$$

where $\{\bar{x}_i, \bar{y}_i\}$ and n are the mean and sample size, respectively, and $\{x_i, y_i\}$ are the individual sample points indexed by i .

if r is equal to or have a value closer to 1 It means that the linear correlation between these variables is high.

to estimate correlation between variables, we use the Pearson correlation analysis method.

Chapter03

The Pearson correlation analysis method evaluates the linear relationship between two variables. If a change in one variable is proportional to a change in the other variable, then there is a linear relationship between these variables. [2]

3.4.2 Collinearity and variable selection

One of the objectives of regression is to try to describe the process of causality between exogenous and endogenous. For this, we study the sign and value of the coefficients. The idea is to circumscribe to the possible the role of such or such variable in explaining the values taken by Y. If it is established that a variable is of no use, it is advisable to eliminate it, it disturbs the reading of the results.

Adding more independent variables does not mean the regression will get better, in fact it can make things worse. The addition of more independent variables creates more relationship among them. So not only are the independent variables related to the dependent variable, they are also potentially related to each other. When it happens, it is called multicollinearity.

We speak of collinearity between 2 exogenous variables when the linear correlation between these variables is high (e.g. $r > 0.8$ is usually indicated as 1 but this is not an absolute rule). We can generalize this first denial by denying the collinearity as the correlation between one of the exogenous with a linear combination of the other exogenous.

There is a real risk of missing an important exogenous variable simply because it is redundant with another. The collinearity between exogenous variables makes the reading of the results illusory. Based on the values and significance of the coefficients. It is advisable to detect it and to process it before any further interpretation.

3.5 SIMPLE LINEAR REGRESSION

The simple linear regression model is an endogenous (dependent) variable explained by a single exogenous (independent) variable put in the following mathematical form:

$$Y_t = \beta_0 + X_t * \beta_1 + \varepsilon_t \quad t=1, \dots, n$$

with:

Y_t : the endogenous (dependent, to be explained) variable at date t;

X_t : the exogenous variable (independent, explanatory) at date t;

β_0, β_1 : the unknown parameters of the model;

ε_t : the random error of the model;

Chapter03

n: number of observations.

We therefore have a sample of n pairs of points (x_i, y_i) independent and identically distributed, and we want to explain (predict) the values of Y according to the values taken by X .

The random term is used to summarize all the information that is not considered in the linear relationship between Y and X (specification problems, approximation of linearity, summarizing the variables that are absent, etc.).

The ε_i quantities come from the fact that the dots are never perfectly aligned on a straight line. They are called errors (or noises) and are assumed to be random.

3.5.1 Assumptions

To be able to say things relevant to this model, assumptions about them must nevertheless be imposed.

These assumptions are as follows:

H1: Assumptions about X and Y . These are numerical quantities measured without error. X is a data (exogenous) in the model, Y is random through (i.e. the only error we have on Y is due to the inadequacies of X in explaining its values in the model).

H2: Assumptions on the random term. The i 's are i.i.d. (independent and identically distributed)

- **(H2.a)** On average the errors cancel each other out, the model is well specified. $E(\varepsilon_i) = 0$
- **(H2.b)** The variance of the error is constant and does not depend on the observation: homoscedasticity $V(\varepsilon_i) = (\sigma_{\varepsilon_i})^2$
- **(H2.c)** In particular, the error is independent of the exogenous variable $COV(x_i, \varepsilon_i) = 0$
- **(H2.d)** Independence of errors, errors relating to 2 observations are independent (it is also said that errors are "uncorrelated") $COV(\varepsilon_i, \varepsilon_j) = 0$
- **(H2.e)** Normal law $\varepsilon_i \equiv N(0, \sigma_{\varepsilon_i})$

3.5.2 least squares method

The estimation of the parameters is obtained by minimizing the sum of the squares of the errors.

$$\text{Min} \sum_{i=1}^n \varepsilon_i^2 = \text{Min} \sum_{i=1}^n (Y_i - \beta_0 - \beta_1 X_i)^2 = \text{Min} \sum_{i=1}^n S^2$$

For this function to have a minimum, the derivatives in relation to β_0 and β_1 must be zero.

Chapter03

$$\frac{\partial S}{\partial \beta_0} = 0 \Leftrightarrow 2 \sum_{t=1}^n (Y_t - \beta_0 - \beta_1 X_t)(-1) = 0 \Rightarrow \sum_{t=1}^n Y_t = n\beta_0 + \beta_1 \sum_{t=1}^n X_t \quad (3)$$

$$\frac{\partial S}{\partial \beta_1} = 0 \Leftrightarrow 2 \sum_{t=1}^n (Y_t - \beta_0 - \beta_1 X_t)(-X_t) = 0 \Rightarrow \sum_{t=1}^n Y_t X_t = \beta_0 \sum_{t=1}^n X_t + \beta_1 \sum_{t=1}^n X_t^2 \quad (4)$$

We note β_0' and β_1' the solutions of (3) and (4):

$$\hat{\beta}_0 = \frac{\sum_{t=1}^n Y_t}{n} - \hat{\beta}_1 \frac{\sum_{t=1}^n X_t}{n} \quad \boxed{\hat{\beta}_0 = \bar{Y} - n\bar{X}}$$

$$\left(\frac{\sum_{t=1}^n Y_t}{n} = \bar{Y} \right) \text{ et } \left(\frac{\sum_{t=1}^n X_t}{n} = \bar{X} \right)$$

because:

$$\boxed{\hat{\beta}_1 = \frac{\sum_{t=1}^n X_t Y_t - n\bar{Y}\bar{X}}{\sum_{t=1}^n X_t^2 - n\bar{X}^2} = \frac{\sum_{t=1}^n (Y_t - \bar{Y})(X_t - \bar{X})}{\sum_{t=1}^n (X_t - \bar{X})^2}}$$

We replace this term in (4), we get:

3.5.3 Different entries in the simple linear regression model

* **The theoretical model (unadjusted model):**

$$Y_t = \beta_0 + \beta_1 X_t + \varepsilon_t$$

* **The estimated model (fitted model):**

$$Y_t = \hat{\beta}_0 + \hat{\beta}_1 X_t + e_t$$

With:

$$\hat{Y}_t = \hat{\beta}_0 + \hat{\beta}_1 X_t$$

And:

Chapter03

$$e_t = Y_t - \hat{Y}_t = Y_t - \hat{\beta}_0 - \hat{\beta}_1 X_t$$

3.5.4 Analysis of variance equation

at what point can it be said that the regression is of "good quality"?

to know that we need to calculate the coefficient of determination as follows:

$$\begin{aligned} e_i &= y_i - \hat{y}_i = (y_i - \bar{y}) - (\hat{y}_i - \bar{y}) \\ &= \sum_{i=1}^n (y_i - \bar{y})^2 = \sum_{i=1}^n (\hat{y}_i - \bar{y})^2 + \sum_{i=1}^n e_i^2 \\ &= SSTO = SSR + SSE \\ R^2 &= \frac{SSR}{SSTO} = \frac{\sum_{i=1}^n (\hat{y}_i - \bar{y})^2}{\sum_{i=1}^n (y_i - \bar{y})^2} \end{aligned}$$

SSTO is the total sum of squares. The greater the variation of \hat{y}_i , the greater is the SSTO. SSE denotes the sum of squared errors, and SSR is the regression sum of squares. [2]

$0 < R^2 < 1$, the closer the value of R^2 is to 1, the more significant the model is.

- if $R^2 = 0$, the model explains nothing, the variables X and Y are not linearly correlated.
- if $R^2 = 1$, the points are aligned on the line, the linear relationship explains all the variation.
- a value of R^2 close to 1 is needed to have a reasonable but by no means sufficient adjustment.

3.6 MULTI LINEAR REGRESSION

The general model is a generalization of the simple model in which there are several explanatory variables:

$$y_1 = \beta_0 + \beta_1 x_{11} + \beta_2 x_{21} + \beta_3 x_{31} + \dots + e_1$$

$$y_2 = \beta_0 + \beta_1 x_{12} + \beta_2 x_{22} + \beta_3 x_{32} + \dots + e_2$$

⋮

$$y_n = \beta_0 + \beta_1 x_{1n} + \beta_2 x_{2n} + \beta_3 x_{3n} + \dots + e_n$$

The superior and independent variables can be described by:

$$y_i = \beta_0 + \beta_1 x_{1i} + \beta_2 x_{2i} + \beta_3 x_{3i} + \dots + e_i$$

In multiple regression, each coefficient is interpreted as the estimated change in Y corresponding to a one-unit change in a variable, when all other variables are held constant.

The coefficient β is estimated by least-squares regression, as follows: [2]

Chapter03

$$\begin{aligned} L &= \min \left[\sum_{i=1}^n e_i^2 \right] = \min \left[\sum_{i=1}^n (y_i - \hat{y}_i)^2 \right] \\ &= (y - X\hat{\beta})' (y - X\hat{\beta}) \\ &= Y'Y - Y'X\hat{\beta} - \hat{\beta}'X'Y + \hat{\beta}'X'X\hat{\beta} \end{aligned}$$

$$\begin{aligned} \frac{\partial L}{\partial \hat{\beta}} &= -2X'Y' + 2X'X\hat{\beta} = 0 \\ \hat{\beta} &= (X'X)^{-1}X'Y. \end{aligned}$$

3.7 SYSTEM STUDIED

To perform our study of prediction we used data from the publication “Analysis and evaluation of the impact of climatic conditions on the photovoltaic modules performance in the desert environment” Corresponding author at: “Unité de Recherche en Energies Renouvelables en Milieu Saharien (URERMS), Centre de Développement des Energies Renouvelables (CDER), 01000 Adrar, Algeria.” All studies presented in this work were performed in the Research Unit in Renewable Energy URERMS Adrar which is situated in the southern-west of Algeria (Latitude 27.88_N, Longitude _0.27_E, Altitude 262 m). The province is characterized by [3]:

- _ High ambient temperature in summer.
- _ High solar irradiance potential.
- _ Low humidity rate.
- _ Large number of clear days in the year.
- _ Small number of dust storm days.

The outdoor PV module performance is carried out with the software and hardware of EKO instruments (MP-160 I–V tracer). This tool is used for the measurement of the IV characteristic curves and main parameters of an individual solar cell. The instrument measures simultaneously the Voltage and current, and also the incident solar irradiance and temperature using a pyranometer and a thermocouple. The acquired data are after that translated at standard test conditions (STC) in order to proceed with the comparison with reference values of performances parameters at STC condition declared by the manufacturer of photovoltaic modules. The CM11 Kipp & Zonen Pyranometer and Type-T thermocouple were used in our experimental tests. The main technical specifications of MP-160 I–V tracer are presented in **Table2**. [4]

Chapter03

Characteristics	Details
Measuring method	Electronic load method
Input Voltage	300 V (Max 320 V)
Input Current	10 A (Max 11 A)
Input Power	300 W (Max 360 W)
Temperature Input	T-type or K-type thermocouple
Irradiation Input	Pyranometer (30 mV)
Sweep Time	2–330 s
Accuracy	+/- 0.5% FS
Resolution	10^{-3} FS
Voltage range	300 V, 30 V, 3 V
Current range	10 A, 3 A, 0.3 A, 0.03 A
Power requirements	AC 100–240 V, 50/60 Hz
Operating conditions	Humidity 0–90% and dry environment

Table 2: specification of the measurement system

The photovoltaic modules ISOFOTON 100 and UDT5 50 are used in these experiments.

3.8 DATA USED FOR THE STUDY

The outline of the first experiment is shading the cells of the first row from the first to the sixth cell of ISOFOTON 100 module. This experiment was carried out in 26-03-2015 from 14:40:11 PM to 14:52:43 PM. **Table3** gives the experimental results of the effect of partial shading on performance parameters. [4]

	P_{max} (W)	V_{max} (V)	I_{max} (A)	FF (%)	η (%)
No shading	79.7	29.57	2.69	63.3	10.87
1 Cell shaded	58.29	22.89	2.44	48.3	7.96
2 Cell shaded	44.17	19.52	2.26	37.5	6.02
3 Cell shaded	34.76	17.02	2.04	29.5	3.93
4 Cell shaded	25.01	13.98	1.79	22.6	2.98
5 Cell shaded	18.57	13.32	1.39	18.7	2.16
6 Cell shaded	16.45	13.27	1.24	17.7	1.89

Table 3: effect of partial shading on PV power generation parameters

ISOFONTON 100 under daily operating condition for different irradiances and temperatures levels were carried out in 2 April 2015 [4] given in **Table4**.

Chapter03

Time	T	G	I_{sc}	V_{oc}	I_{max}	V_{max}	P_{max}	FF	η
09 :17 :32 AM	33.5	398	1.57	37.72	1.29	29.14	37.58	66.3	11.03
09 :52 :50 AM	37.5	451	2.06	37.55	1.71	28.73	49.23	63.5	12.76
10 :38 :02 AM	26.7	585	2.6	37.08	2.15	28.18	60.84	63	12.14
13 :50 :01 PM	56.4	896	3.37	35.88	2.72	27.73	74.43	61.4	9.7
14 :30 :00 PM	58.6	1050	3.12	35.44	2.59	26.95	69.85	61.3	7.77
15 :10 :00 PM	54.6	790	2.92	35.9	2.39	27.21	65.12	62	9.63
15 :50 :00 PM	53.7	729	2.54	35.85	2.06	27.67	57	62.5	9.13

Table 4: The performance parameters under different levels of solar irradiation and temperatures.

3.9 PREDICTION MODEL OF PV POWER

For the prediction of our models we used both softwares ORIGIN and EXCEL to do the correlation analysis, calculate the variables needed to select the input variables of the PV power predictive model, draw the regression line and finally obtain the predictive model.

3.9.1 Pre-work

- List of potential variables.
- Collect data.
- Check the relationship between each independent variable and the dependent variable using scatterplots and correlation.
- Check the relationship among independent variables using scatterplots and correlation.
- Conduct simple linear regression for each independent/dependent pair.
- Use the non-redundant independent variable in the analysis to find the best fitting model.
- Use the best fitting model to make prediction about the dependent variable

Before we start, it is first necessary to introduce some important variables used for the explanation and determination of the model.

* **p-value:**

which stands for probability value, is a statistical measure between 0 and 1 and is used for hypothesis testing.

A significance level must be established before data collection begins and is usually defined as 5% (or 0.05). However, other levels may be used depending on the study.

If a p-value less than or equal to the significance level is generated, the result is considered statistically significant (and rejects the null hypothesis). This is usually written as $p \leq 0,05$.

Chapter03

In calculating the p-value, we begin by assuming that there is really no true difference between the two treatments tested.

- * **Multiple R:** it is the correlation coefficient.
- * **R square:** percentage of variation in the dependent variable accounted by the independent variable.
- * **Adjusted R square:** same as R square but adjusted for the number of independent variables, so it will always be lower than the R square.

3.9.2 Results and discussion

3.9.2.1 Prediction of the maximum PV power as a function of number of cells shaded (simple linear regression)

Photovoltaic modules are very sensitive to shading. They cannot be shaded, mainly because of the electrical connections (in series) between the cells and between the modules.

In this first model, number of cells shaded is considered as the independent variable (X), while the maximum power is the dependent one (Y) as shown in **Table5**.

the results of the two simulation were the same in both Origin and Excel. Showing a negative relation between the two variables. We can see that clearly in the scatter plots and regression lines (**figure43, figure44**) as well as in the simulation results (**figure45, figure46**).

- The correlation coefficient (referred to as R in Origin and multiple R in excel) $r = 0.96441...$ it is very close to 1 which means that there is a strong correlation (the two variables are strongly associated). It is indicated with a sign negative; we can interpret that as:
 - high values of X generally correspond to low values of Y.
 - the mean values of X generally correspond to the mean values of Y.
 - low values of X generally correspond to high values of Y.
- The Pearson coefficient value is $P = 0.00045$ which is a lot smaller than the significant value 0.005 this explains that the result is considered statistically significant.
- The equation coefficients are:
 - $\beta_0 = 70.45893...$ (referred to as A in Origin and as intercept in Excel)
 - $\beta_1 = -10.29821...$ (referred to as B in Origin and number of cells shaded in Excel)
- The coefficient of determination $R^2 = 0.9301$ (referred to as R square in Excel), R^2 is close to 1 this tells the reliability of our model.

Finally, the predictive model is:

$$Y = -10.982X + 70.459$$

Chapter03

In other terms:

$$P_{\max} = -10.982(\text{NCS}) + 70.459$$

The number $\beta_0 = 70.459$ represents the value of the maximum power if the number of cells shaded was in fact zero.

The number $\beta_1 = -10.982$ which is the gradient of our equation/ regression line, is an estimated change in P_{\max} corresponding to a unit change in NCS (Number of cells shaded). This means that if the number of cells shaded increases by one, the maximum power will decrease by -10.982 W.

3.9.2.1.1 Data used for the first predictive model

Number of cells shaded (X)/ independent variable	Maximum power (Y) (W)/ dependent variable
0	79.7
1	58.29
2	44.17
3	34.76
4	25.01
5	18.57
6	16.45

Table 5: Variation of the maximum power as a function of the number of cells shaded

3.9.2.1.2 Scatter plot and regression line

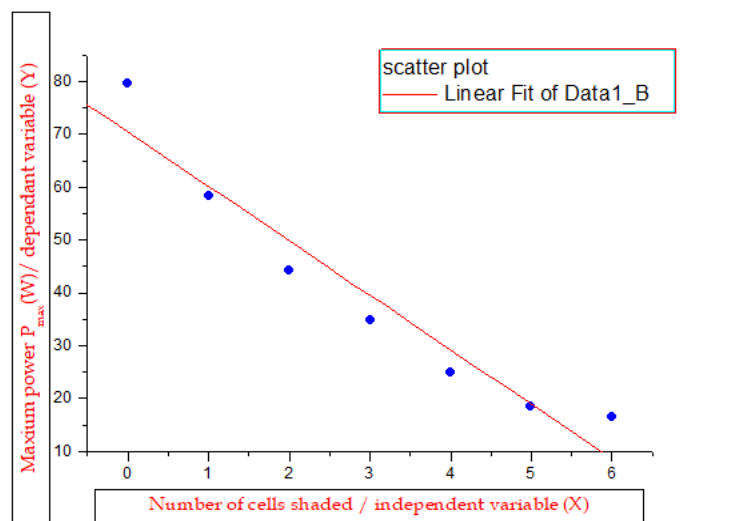

Figure 43: scatter plot and regression line on Origin

Chapter03

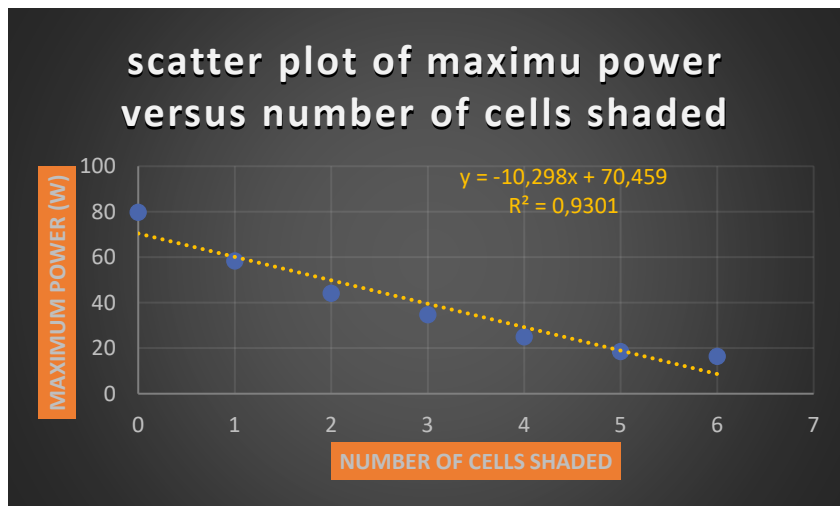

Figure 44: scatter plot and regression line on excel

3.9.2.1.3 Parameters

Results Log			
[02/06/2020 17:21 "/Graph1" (2459002)]			
Linear Regression for Data1_B:			
Y = A + B * X			
Parameter	Value	Error	
A	70,45893	4,55244	
B	-10,29821	1,26262	
R	SD	N	P
-0,96441	6,68115	7	4,50128E-4

Figure 45: parameters simulated in Origin

SUMMARY OUTPUT								
Regression Statistics								
Multiple R	0,964413543							
R Square	0,930093483							
Adjusted R Square	0,916112179							
Standard Error	6,681153825							
Observations	7							
ANOVA								
	df	SS	MS	F	Significance F			
Regression	1	2969,490089	2969,49	66,52409	0,000450128			
Residual	5	223,1890821	44,63782					
Total	6	3192,679171						
	Coefficients	Standard Error	t Stat	P-value	Lower 95%	Upper 95%	Lower 95,0%	Upper 95,0%
Intercept	70,45892857	4,55243896	15,47718	2,04E-05	58,75651167	82,16134547	58,75651167	82,16134547
Number of cells shaded	-10,29821429	1,262619392	-8,15623	0,00045	-13,5438808	-7,05254781	-13,54388076	-7,052547811

Figure 46: parameters simulated in Excel

Chapter03

3.9.2.2 Prediction of the maximum PV power as a function of temperature and solar radiation (multiple linear regression)

3.9.2.2.1 Data used for the second predictive model

T(°c)	G(W/m ²)	Pmax (W)
33,5	398	37,58
37,5	451	49,23
26,7	585	60,84
56,4	896	74,43
58,6	1050	69,85
54,6	790	65,12
53,7	729	57

Table 6: Variation of the maximum power as a function of the number of cells shaded

3.9.2.2.2 Relationship between independent variables

-The correlation analysis between the independent variables shows that there is a strong correlation between them, which is not good for our model, giving a r value of r= 0.8.

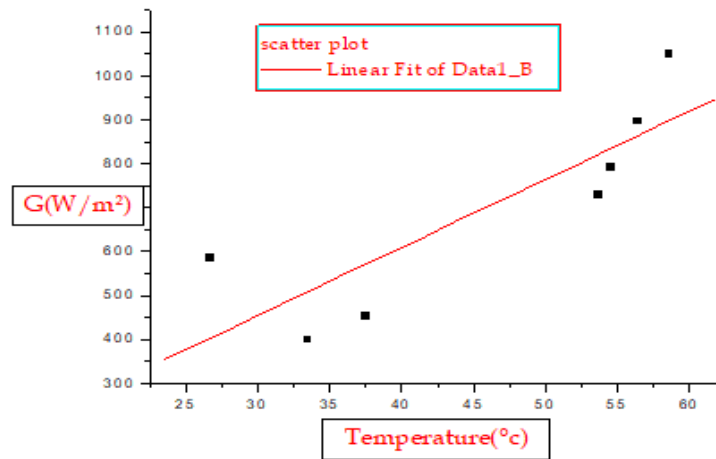

Figure 47: scatterplot and regression line of T and G

Chapter03

3.9.2.2.3 Parameters

Linear Regression for Data1_B:
 $Y = A + B * X$

Parameter	Value	Error
A	-12,79725	205,95096
B	15,54075	4,34581

R	SD	N	P
0,84789	137,49639	7	0,01594

Figure 48: results of parameters simulation on origin

3.9.2.3 Relationship between each independent variable and the dependent using scatterplots and correlation

3.9.2.3.1 T and Pmax

-In correlation analysis (figure47) it is suggested that when the temperature increase, there is a practical increase in the maximum power. However, in reality it is not true, the correlation is negative.

-Under constant solar radiation conditions, power generation decreases as the temperature of the photovoltaic modules increases. The power output of crystalline PV modules typically reduces by 0.4% per 1 °C increase in the temperature, but at installation sites, both Pmax and temperature increase with the irradiation [2].

-The correlation coefficient is equal to $r = 0.66473$ is it a bit far from 1 and that confirms the practical results, meaning the correlation or relation between Pmax and T is negative.

-To decide whether to take the temperature as a potential variable or not, our final parameter is the P-value it is equal to $P = 0.10331 > 0.005$ from this value it is easy to eliminate the temperature variable from the model(also, when simulating the two variable in Excel we found that T has a P-value that exceed 0.005 (Figure51 shown in red)).

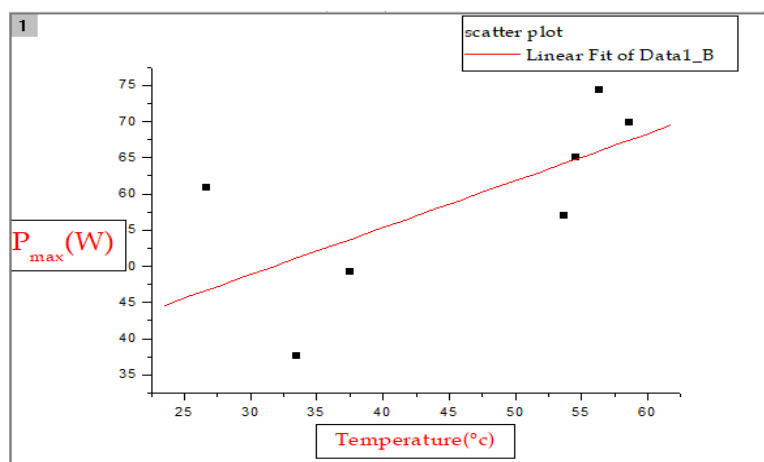

Figure 49: scatterplot and regression line of T and Pmax on Origin

Chapter03

3.9.2.3.2 Parameters

[02/06/2020 20:54 "/Graph1" (2459002)]
 Linear Regression for Data1_B:
 $Y = A + B * X$

Parameter	Value	Error
A	29,38015	15,46341
B	0,64919	0,3263

R	SD	N	P
0,66473	10,32363	7	0,10331

Figure 50: results of regression parameters simulation on Origin

SUMMARY OUTPUT									
Regression Statistics									
Multiple R		0,910110161							
R Square		0,828300506							
Adjusted R Square		0,742450758							
Standard Error		6,401790216							
Observations		7							
ANOVA									
		df	SS	MS	F	Significance F			
Regression		2	790,8275281	395,4138	9,648258	0,029480716			
Residual		4	163,9316719	40,98292					
Total		6	954,7592						
		Coefficients	Standard Error	t Stat	P-value	Lower 95%	Upper 95%	Lower 95,0%	Upper 95,0%
Intercept		30,17966975	9,592715698	3,146103	0,034644	3,546021207	56,8133183	3,54602121	56,8133183
T(°c)		-0,32173156	0,381644772	-0,84301	0,44668	-1,381347318	0,737884198	-1,3813473	0,737884198
G(W/m²)		0,062475636	0,020822129	3,000444	0,039924	0,004664139	0,120287134	0,00466414	0,120287134

Figure 51: simulation of both T and G with Pmax on Excel

3.9.2.3.3 G and pmax

-Pmax and G shows a correlation coefficient of 0.89319... (figure54, figure55) which indicates a high degree of association between these two variables.

-And so, we can finally decide on which variable to take for our model.

-The model coefficients are:

$\beta_0=25.842$, $\beta_1=0.0476$ (figure54, figure55) and we have as well a strong $R^2= 0.7978$ the model is:

$$Y = 0,0476X + 25,842$$

In other terms

$$P_{\max}=0.0476G+25.842$$

The number $\beta_0= 25.842$ represents the value of the maximum power if the amount of solar radiation was in fact zero.

Chapter03

The number $\beta_1 = 0.0476$ which is the gradient of our equation/ regression line, is an estimated change in P_{max} corresponding to a unit change in G . This means that if the amount of solar radiation increases by 1W/m^2 , the maximum power will increase by 0.0476 W .

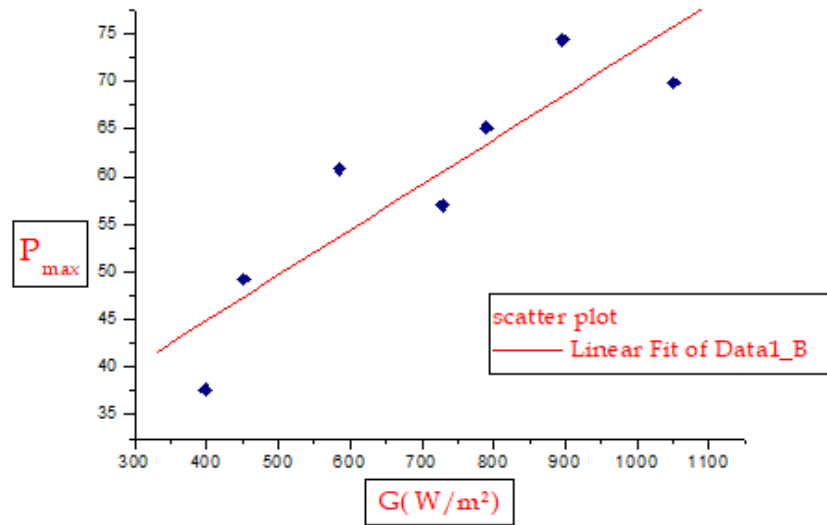

Figure 52: scatter plot and regression line of G and Pmax on Origin

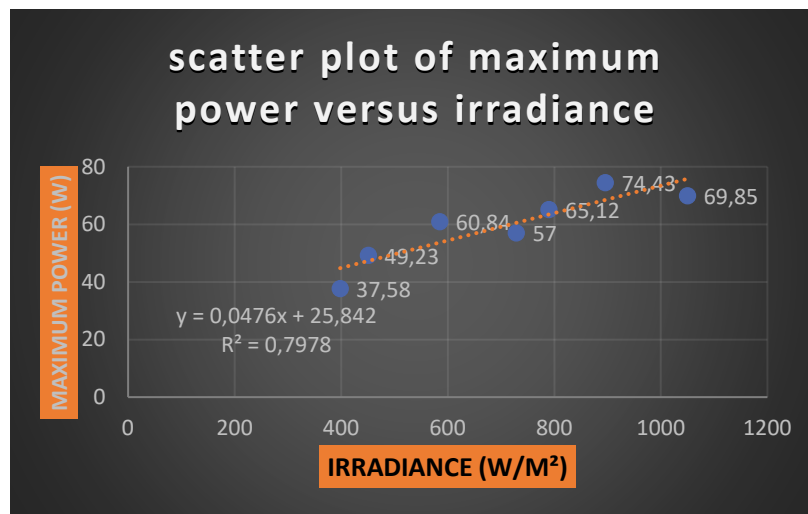

Figure 53: scatter plot and regression line of the corrected modal on excel

Chapter03

3.9.2.3.4 Parameters

[02/06/2020 22:17 "/Graph1" (2459002)]
 Linear Regression for Data1_B:
 $Y = A + B * X$

Parameter	Value	Error
A	25,84212	7,85832
B	0,04759	0,01072

R	SD	N	P
0,89319	6,21381	7	0,00676

Figure 54: results of parameters simulation on Origin

SUMMARY OUTPUT									
Regression Statistics									
Multiple R		0,893193728							
R Square		0,797795036							
Adjusted R Square		0,757354043							
Standard Error		6,213808012							
Observations		7							
ANOVA									
		<i>df</i>	<i>SS</i>	<i>MS</i>	<i>F</i>	<i>Significance F</i>			
Regression		1	761,70215	761,7021	19,72738	0,006755116			
Residual		5	193,05705	38,61141					
Total		6	954,7592						
		<i>Coefficients</i>	<i>Standard Error</i>	<i>t Stat</i>	<i>P-value</i>	<i>Lower 95%</i>	<i>Upper 95%</i>	<i>Lower 95,0%</i>	<i>Upper 95,0%</i>
Intercept		25,84211604	7,85832229	3,288503	0,021749	5,641655505	46,04257658	5,64165551	46,04257658
G(W/m ²)		0,047592404	0,010715264	4,441552	0,006755	0,020047941	0,075136868	0,02004794	0,075136868

Figure 55: final parameters simulation on excel

Chapter03

3.10 CONCLUSION

In this chapter, dedicated for the study and the prediction of the influence of Temperature, Solar irradiance and the shading on solar cells, on the photovoltaic power; we presented a review on the concepts and laws dedicated to the prediction and prevision of a component by general. A statistical methodology based on linear regression for assessing photovoltaics module reliability was presented.

Two equations for estimating the photovoltaic power of modules have been proposed. They use the database of environmental conditions at the module exposure site.

In the first model, we used simple linear regression as we had only one independent variable, Number of cells shaded (NCS), the results indicate that Photovoltaic modules are very sensitive to shading, if the number of cells shaded increases by one cell, the maximum power will decrease by -10.982 W, high values of NSC generally correspond to low values of P_{max} , the mean values of NSC generally correspond to the mean values of P_{max} , low values of NSC generally correspond to high values of P_{max} .

In the second model, we found out that there is a strong correlation between solar irradiance and temperature with a correlation factor of $r=0.84789$, these two variables are redundant. We excluded the variable which has a p-value that exceeds 0.005 which is temperature also, under constant solar radiation conditions, power generation decreases as the temperature of the photovoltaic modules increases. So, the model equation is composed only of G (W/m^2) which was highly correlated with P_{max} . this indicates a decrease in prediction error caused by increasing number of variables that have high correlation coefficients [2]. In this model we started out with multiple linear regression but ended up with simple linear regression with the result: when solar radiation increases by $1W/m^2$, the maximum power will increase by 0.0476 W.

Chapter03

3.1 | REFERENCES

- [1] Cornillon PA., Matzner-Løber E. (2011) La régression linéaire simple. In: Régression avec R. Collection Pratique R. Springer, Paris
- [2] Gyu Gwang Kim, Jin Ho Choi, So Young Park, Byeong Gwan Bhang, Woo Jun Nam, Hae Lim Cha, NeungSoo Park, Hyung-Keun Ahn. "Prediction Model for PV Performance With Correlation Analysis of Environmental Variables". IEEE JOURNAL OF PHOTOVOLTAICS, VOL. 9, NO. 3, MAY 2019
- [3] Zerrouki Moussa, Settou Nouredine, Marif Yacine, Belhadj Mohamed Mustapha. Simulation study of a capillary film solar still coupled with a conventional solar still in south Algeria. Energy Convers Manage 2014;85:112–9.
- [4] Ahmed Bouraiou, Messaoud Hamouda, Abdelkader Chaker, Mohammed Mostefaoui, Salah Lachtar, Mohammed Sadok, Nadir Boutasseta, Mourad Othmani, Attoui Issam, Analysis and evaluation of the impact of climatic conditions on the photovoltaic modules performance in the desert environment, Energy Conversion and Management, Volume 106, 2015, Pages 1345-1355, ISSN 0196-8904.
- [5] N. H. Reich, B. Mueller, A. Armbruster, W. G. Sark, K. Kiefer, and C. Reise, "Performance ratio revisited: Is $p_r > 90\%$ realistic?" *Prog. Photovolt., Res. Appl.*, vol. 20, pp. 717–726, 2012.
- [6] J. A. Duffie, and W. A. Bechman, *Solar Engineering of Thermal Processes*, 3rd ed. Hoboken, NJ, USA: Wiley, 2006.

General Conclusion

GENERAL CONCLUSION

Environmental protection along with meeting the rising demand of energy, have become major concerns these days. In the last few years, numerous avenues of research have therefore been directed towards the use of renewable energies, including solar energy.

Solar energy is a real and efficient alternative to fossil fuels in several ways, it is inexhaustible, it can be produced locally and, depending on local needs, it can be used in a variety of ways. It preserves the environment because it does not emit greenhouse gases, does not produce waste and involves no major risk and no significant nuisance. This energy is produced by a device (photovoltaic solar cell or photo pile) that transforms electromagnetic solar radiation into electrical energy.

However, this device could be easily influenced by external parameters like shading and especially irradiance and temperature since it functions through sunlight. The negative effect of these parameters is that the solar cells would inherent low efficiency conversion rate and that could result major losses, mainly high-priced maintenance. Therefore, the most important investment decision when it comes to implementing photovoltaic (PV) array(s) either for commercial or private application, is the leveled cost of energy. This draw back, makes it quite crucial that output power and performance prediction of Photovoltaic systems at module level are established.

This thesis is part of a desire to bring more visibility and reliability to PV energy, which is growing extremely rapidly and already represents a significant share of electricity worldwide. Its main objective is to understand and study the influence of external parameters on the operation of PV cells.

We have recalled, first of all, generalities about the fundamental source of photovoltaic energy, the sun. Plus, some fundamentals of photovoltaics.

After that, we described the photovoltaic converters, their I-V characteristic, their equivalent electrical circuitry and their main quantities characteristics as well as the study of the influence of the various parameters (illumination, the temperature, series and parallel parasitic resistances, saturation current and the factor of ideality).

after finishing with these contexts, we moved to the simulation and result discussion. To perform our study, we used data from the publication “Analysis and evaluation of the impact of climatic conditions on the photovoltaic modules performance in the desert environment” Corresponding author at: “Unité de Recherche en Energies Renouvelables en Milieu Saharien (URERMS), Centre de Développement des Energies Renouvelables (CDER), 01000 Adrar, Algeria.” With the photovoltaic modal ISOFOTON 100.

General Conclusion

The prediction method uses regression and correlation analysis of long-term data on PV module power. It is a statistical method of investigation based on observational or experimental data, in which the main objective is to search for a linear relationship between a variable Y and one or more X other variables that may or may not be related to Y.

Two predictive models were established, the first forecasts the maximum power in function of the number of cells shaded. The second model predict the maximum power in function of the irradiance since the temperature was excluded because it's correlation with P_{\max} was found small.

To conclude, our perspective is to make a similar study for other types of cells, especially organic solar cells and we envisage Dye-Sensitized Solar Cells or Gratzel cells because the substitution of the photovoltaic of silicon by organic materials is considered a promising alternative with the considerably development of the photovoltaic market; for various reasons: low cost, unlimited raw material, ease of implementation, technology of low temperature, large surfaces, flexible devices...

Abstract

In the framework of this Master thesis, we will focus on photovoltaic solar energy as part of renewable energies. The latter is particularly interesting as it is infinite, the most abundant, fairly distributed, and mainly, for the fact that Algeria has about 3200 hours of sunshine per year, benefiting from a climatic situation favorable to the application of solar techniques. However, Cell efficiency and performance stability carry on being a major concern in this field. The main objective of this study is to prob the impact of environmental conditions on the performance of photovoltaic cells of modules installed in the desert region in south of Algeria. The work developed in this thesis concerns the study of photovoltaic (PV) modules in real conditions of use (outdoors). Our work will be carried out by simulation on the software Origin and comparing its results to others obtained on excel, it embodies the prediction of maximum power of cells contained in the photovoltaic modal ISOFOTON 100. Based on known environmental input data the correlation between the environmental variables and PV power is calculated. In this research, all available data are used to predict the PV power. Meteorological and power data are examined using a statistical approach to identify the order of significance of the input variables. TWO predictive models are suggested as a function of irradiance and number of cells shaded. Based on the system studied the modals predict that the value of the maximum power if the number of cells shaded was in fact zero is 70.459 W, if the number of cells shaded increases by one, the maximum power will decrease by -10.982W and that if the amount of solar radiation increases by $1W/m^2$, the maximum power will increase by 0.0476 W.

Résumé

Dans le cadre de cette thèse de master, nous nous concentrerons sur l'énergie solaire photovoltaïque dans le cadre des énergies renouvelables. Cette dernière est particulièrement intéressante car elle est infinie, la plus abondante, équitablement répartie, et surtout, pour le fait que l'Algérie compte environ 3200 heures d'ensoleillement par an, bénéficiant d'une situation climatique favorable à l'application des techniques solaires. Cependant, l'efficacité et la stabilité des performances des cellules restent une préoccupation majeure. L'objectif principal de cette étude est d'étudier l'impact des conditions environnementales sur la performance des cellules photovoltaïques des modules installés dans la région désertique du sud de l'Algérie. Les travaux développés dans cette thèse concernent l'étude des modules photovoltaïques (PV) en conditions réelles d'utilisation (en extérieur). Nos travaux seront réalisés par simulation sur le logiciel Origin et en comparant ses résultats à d'autres obtenus sur Excel, il incarne la prédiction de la puissance maximale des cellules contenues dans le module photovoltaïque ISOFOTON 100. Sur la base des données environnementales connues, la corrélation entre les variables environnementales et la puissance photovoltaïque est calculée. Dans cette recherche, toutes les données météorologiques disponibles sont utilisées pour prédire la puissance PV. Les données météorologiques et de puissance sont analysées à l'aide d'une approche statistique pour identifier l'ordre de signification des variables d'entrée. Deux modèles prédictifs sont proposés en fonction de l'irradiation et du nombre de cellules ombragées. Sur la base du système étudié, les modèles prédisent que la valeur de la puissance maximale si le nombre de cellules ombragées était en fait nul est de 70,459 W, que si le nombre de cellules ombragées augmente de 1, la puissance maximale diminuera de -10,982 W et que si la quantité de rayonnement solaire augmente de $1W/m^2$, la puissance maximale augmentera de 0,0476 W.

ملخص

في إطار هذه الأطروحة، سنركز على الطاقة الشمسية كجزء من الطاقات المتجددة. هذه الأخيرة مثيرة للاهتمام بشكل خاص لأنها لا نهائية، والأكثر وفرة، و موزعة بشكل عادل، وبشكل رئيسي لأن الجزائر لديها حوالي 3200 ساعة من أشعة الشمس في السنة مستفيدة من الوضع المناخي المواتي لتطبيق تقنيات الطاقة الشمسية. لكن تظل كفاءة الخلية الشمسية واستقرار الأداء مصدر قلق رئيسي. فلذلك الهدف من هذه الدراسة هو دراسة تأثير الظروف البيئية على أداء الخلية الكهروضوئية في الوحدات الصحراوية في جنوب الجزائر. يتعلق العمل الذي تم في هذه الأطروحة بظروف استخدام حقيقية. سيتم تنفيذ عملنا عن طريق المحاكات باستخدام برنامج أوريجين ومقارنة نتائجه بنتائج أخرى تم الحصول عليها عن طريق برنامج اكسال.

عملنا يكمن في تجسيد التنبؤ بالقدرة القصوى للخلايا. سنأخذ بعين الاعتبار العديد من المعلمات مثل الإضاءة و درجة الحرارة. يتم حساب الارتباط بين هذه المتغيرات و الطاقة القصوى. يتم بعد ذلك تحليل بيانات الأرصاد الجوية باستخدام نهج احصائي ثم يقترح نموذجان تنبؤيان للطاقة القصوى. استنادا الى النظام المدروس تتنبأ الوسائط بأ، قيمة الطاقة القصوى اذا كان عدد الخلايا المظللة معدوما هو 70,459 وات، أما اذا زاد عدد الخلايا المظللة بمقدار واحد فان الطاقة تنخفض بمقدار -10.987 وات، و اذا زادت كمية الإشعاع بمقدار 1 وات/م² ستزيد الطاقة القصوى بمقدار 0.0476 وات

